

# 2 1/2 in. Air motor chassis high pressure pump 50:1

Model 82050, series "J"

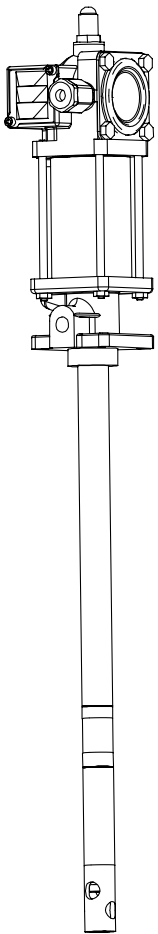

Date of issue	July 2015
Form number	403510S

Read manual prior to installation or use of this product. Keep manual nearby for future reference.

## Specifications

Air motor effective diameter	2.5 in. (63,5 mm)
Air inlet	1/4 in. NPTF
Material outlet	1/4 in. NPTF
Ratio	50:1
Delivery output	80 in. <sup>3</sup> /min. (1 310 cm <sup>3</sup> /min)
Delivery	0.35 in. <sup>3</sup> .min. (5,7 cm <sup>3</sup> )
Minimum air pressure	30 psi (2 bar)
Maximum air pressure	150 psi (10 bar)
Maximum output pressure	7500 psi (517 bar)
Noise level at 120 psi (8 bar)	<85 dB(A)

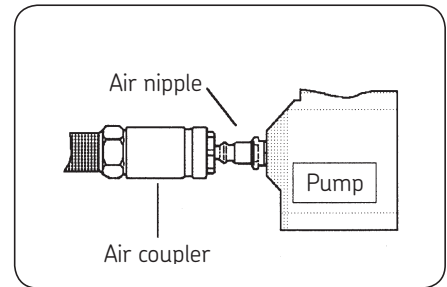

## Description

Model 82050 is an air operated chassis pump designed to pump low and medium viscosity materials (grease) from drums and pails.

## Owner/operator Responsibility

It is the owners/operators responsibility to properly use and maintain this equipment.

The instructions and warnings contained in this manual shall be read and understood by the owner/operator prior to operating this equipment.

It is the owners/operators responsibility to maintain the legibility of all warning and instruction labels.

The owner/operator shall retain this manual for future reference to important warnings, operating and maintenance instructions.

## Safety information

Read and understand all warnings, cautions and instruction before operating this equipment. Extreme caution should be used when operating this equipment as personal injury and/ or property damage can result from equipment misuse. Adequate personal protection is recommended to prevent splashing of material on the skin or in the eyes. **Always** disconnect air coupler from pump when the pump is not being used.

### ⚠ WARNING

**Failure to heed the following warnings including misuse, over pressurizing, modifying parts, using incompatible chemicals and fluids, or using worn or damaged parts, may result in equipment damage and/or serious personal injury, fire, explosion, or property damage.**

- **Do not** exceed the stated maximum working pressure of the pump, or of the lowest rated component in your system.
- **Do not** alter or modify any part of this equipment.
- **Do not** operate this equipment with combustible gas.
- **Do not** attempt to repair or disassemble the equipment while the system is pressurized.
- Make sure all grease connections are securely tightened before using this equipment.

- Always read and follow the grease manufacturers recommendations regarding grease compatibility, and the use of protective clothing and equipment.
- Check all equipment regularly and repair or replace worn or damaged parts immediately.
- Never point the dispensing valve at any part of the body or at another person.
- Never try to stop or deflect material from dispensing valve or leading connection or component with your hand or body.
- Always check equipment for proper operation before each use, making sure safety devices are in place and operating properly.
- Always follow the pressure relief procedure after shutting off the pump, when checking or servicing any part of the system, and when installing, cleaning or changing any part of the system.

## Installation

Typical drum and pail hookups are described as follows only as a guide in selecting and installing a system.

Contact a Lincoln factory representative for assistance in designing a system for a specific requirement.

### ⚠ WARNING

**Do not** exceed maximum working pressure of lowest rated component in system.

Pump can develop 7,500 psi (517 bar) working pressure at 150 psi (10 bar) maximum incoming air pressure. All system equipment and accessories must be rated to withstand maximum working pressure of pump.

Failure to comply may result in death or serious injury.

### ⚠ WARNING

**Do not** exceed 90 PSI (6 bar) air pressure to pump when using whip' hoses. Accessory item whip hoses for dispensing valve are rated at 4,500 psi (310 bar).

Failure to comply may result in serious injury or death.

## Typical system hookup

Determine the drum or pail system for your requirement.

Obtain an air line filter/regulator/lubricator to use with the inlet air supply and the correct sized air and grease lines hoses with any required reducers, connectors and accessories.

Clean/flush the supply lines, hoses, reducers, connectors and accessories with mineral spirits or oil based solvent to purge any contaminants such as dirt, moisture, or metal shavings that could damage the pump or system components. Blow dry with air.

### ⚠ Notice

Pump was tested in lightweight oil and was left in to prevent corrosion.

Flush pump before connecting to system to prevent possible contamination of grease being pumped.

### ⚠ WARNING

**Do not** flush pump with solvents without pump being grounded.

Splashing or static sparking when flushing the pump with solvents can cause an explosion.

Always hold a metal part of dispensing valve firmly to side of a grounded metal pail and operate pump at lowest possible fluid pressure.

Failure to comply may result in death or serious injury.

- Clean/flush the pump with mineral spirits or oil based solvents if necessary.
- Assemble the cleaned pump and supply line together with any required accessory.
- Mount the assembled pump to the drum or pail.
- Connect the material output line/hose to the pump.
- Connect the air regulator to the pump.
- Make sure all connections are securely tightened.

## Accessories

- Filter/regulator/lubricator and gauge.
- Eyebolt kit.
- Follower plate - 120 lb., 400 Lb. (54.4 kg, 181,4)
- Drum cover - 120 lb., 400 Lb. (54.4 kg, 181,4)
- Drum cover with tie rods.
- 1709 Hoist.

## Pressure relief procedure

Always perform this procedure when the pump is shut off and before checking, servicing, installing, cleaning or repairing any part of this system.

Perform the following procedure:

- 1 Disconnect the air supply to the pump.
- 2 Point the dispensing valve away from yourself and others.
- 3 Open the dispensing valve into an appropriate container until the pressure is relieved.

If the above procedure does not relieve the pressure, the dispensing valve or hose may be restricted. To relieve the pressure, very slowly loosen the hose end coupling. Then loosen completely and clear the dispensing valve and/or hose.

## Operation

### Inspection before using pump

Prior to operation or maintenance a visual inspection shall be made. Check pump system for leaks, worn or missing parts.

Any pump that appears to be damaged in any way, is badly worn or operates abnormally shall be removed from use until repairs are made. Contact a factory authorized service center for repairs.

If over pressurizing of the equipment is believed to have occurred, contact a factory authorized service center for inspection of the pump.

Annual inspection by a factory authorized service center is recommended.

**⚠ WARNING**

**Do not** operate pump or system with pressure applied. Perform pressure relief procedure prior to starting pump.

Failure to comply may result in death or serious injury.

To start pump, turn on the main air supply. Slowly open the air regulator. Regulate air pressure from 20 to 40 psi (1,3 to 2,7 Nm) and throttle to prime pump. Open the dispensing valve to allow air to be purged from the system. Allow pump to cycle until grease without air pockets flows from dispensing valve, then close dispensing valve.

After pump is primed, adjust air pressure to achieve a smooth flow of grease from the dispensing valve. **Do not** allow pump to operate when out of material. Pump will accelerate quickly and run too fast, resulting in costly damage to the pump.

If the pump accelerates quickly or is running too fast, stop it immediately. Check the grease supply and refill it if necessary. Prime the pump to remove all air from the system, or flush the pump and relieve pressure.

In a circulating system, the pump runs continuously and slows down or speeds up as supply demands, until the air supply is shut off.

In a direct supply system, with adequate air pressure supplied to the motor, the pump starts when the gun or dispensing valve is opened and stalls against pressure when it is closed.

Use the air regulator to control pump speed and grease pressure. Always use the lowest pressure required to achieve the desired results. Higher pressures will cause pump packing to wear prematurely.

## Maintenance

**⚠ WARNING**

**Do not** perform maintenance on pump or system with **pressure applied**

Failure to comply may result in death or serious injury.

## Lubrication

An air line filter/regulator/lubricator is recommended for use with your Lincoln pump to remove harmful dirt and moisture from your compressor air supply, and to provide automatic air motor lubrication.

If an air line lubricator is not used, the following procedure should be performed daily:

- 1 Disconnect air coupler from air fitting.
- 2 Fill air coupler with 10 SAE motor oil and reconnect to air fitting.
- 3 Operate pump to distribute lubricant.

## Material restriction prevention

Flush the system as required with a compatible solvent to prevent material buildup, when pumping material that will dry or harden.

## Corrosion prevention

**⚠ WARNING**

**Do not** flush pump with solvents without pump being grounded.

Splashing or static sparking when flushing the pump with solvents can cause an explosion.

Always hold a metal part of dispensing valve firmly to side of a grounded metal pail and operate pump at lowest possible fluid pressure.

Failure to comply may result in death or serious injury.

To prevent water or air corrosion, never leave the pump filled with water or air. Flush the pump first with a compatible solvent and then again with mineral spirits or oil based solvent.

**⚠ WARNING**

**Do not** disassemble or assemble pump with pressure applied to pump or system.

Relieve all pressure from system before and after use of pump.

Failure to comply may result in death or serious injury.

## Dimensions

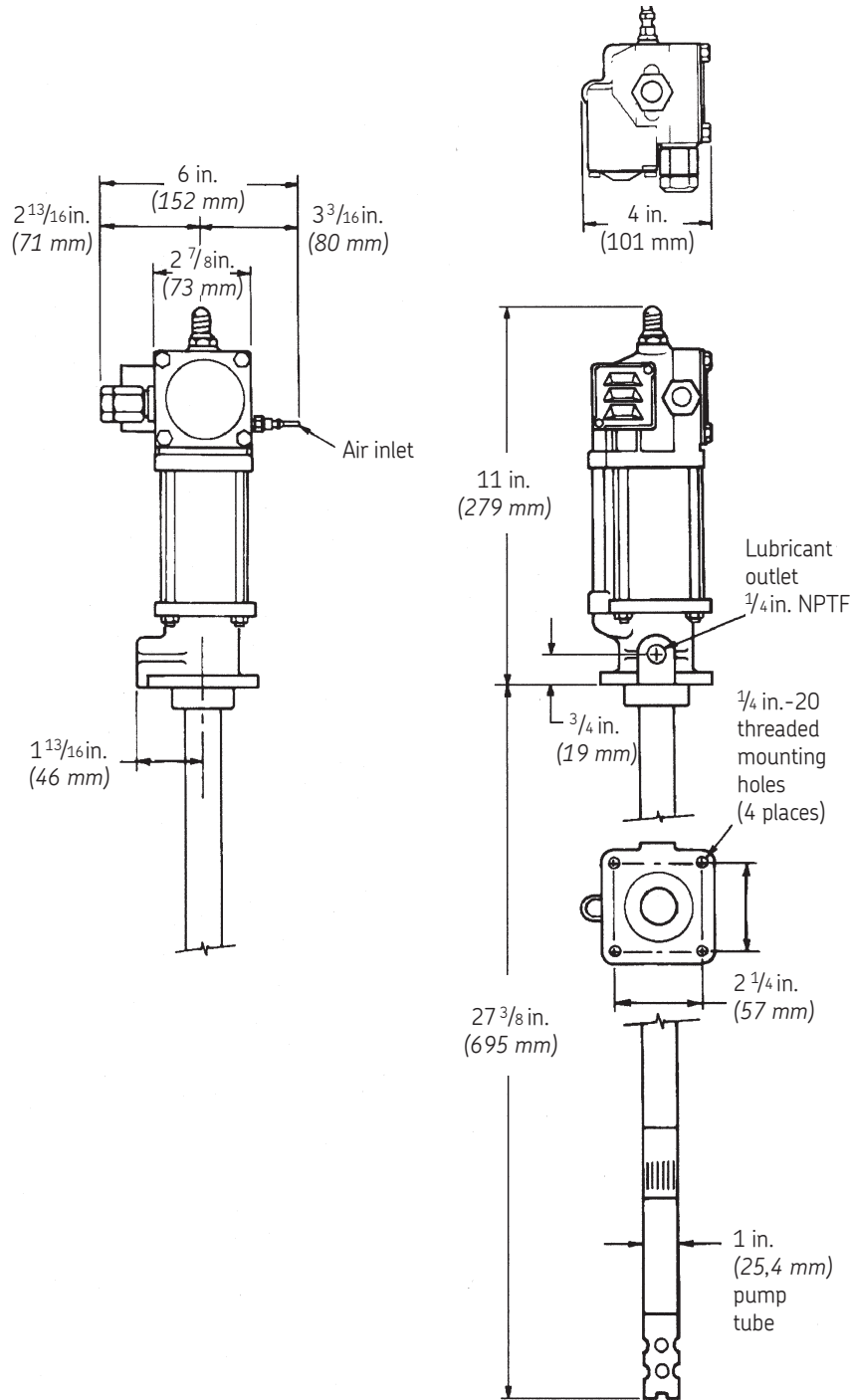

## Disassembly

### ! Notice

If complete disassembly is required, order repair kit and replace **all** gaskets, o-rings and packings.

- 1 Remove valve cap (12) and trip rod pin (11).
- 2 Unscrew four nuts (65) from tie rods (66) and remove trip rod collar (13).
- 3 Unscrew trip sleeve (8) from trip rod (31) and lift air valve casting (9) off of air cylinder (34).
- 4 Remove packing nut (68) and packing cap (71) from air valve casting.
- 5 Remove four valve cover screws (15) and cover (62).
- 6 Remove four toggle plate screws (16), toggle assembly (63) and trip shoe (64).
- 7 Remove four valve seat screws (61), springs (60), valve guide plate (59) and valve slide seat and gasket (58).
- 8 Unscrew trip rod packing nut (20) from air valve casting and remove all packing parts.
- 9 Unscrew pump tube from outlet body (33).
- 10 Remove air cylinder (34) and air passage tube (35) from outlet body.
- 11 Extend air motor piston rod (1) out bottom of outlet body. Place wrenches on air piston bolt (2) and on wrench flats of piston rod and unscrew piston rod. Thread piston rod through gland packing to allow removal of pump tube.
- 12 Unscrew gland packing nut (21) from outlet body and remove all gland parts.
- 13 Remove priming tube (50) from bushing extension (51).

- 14 Extend plunger rod (43) out bushing extension and unscrew priming plunger (49) to allow removal of priming check parts and plunger rod (43).
- 15 Remove bushing extension (51) and unscrew plunger and bushing assembly (40) from pump tube. Unscrew coupling nut (36) from plunger adapter (53) to allow removal of plunger and bushing assembly intact, reducing the chance of losing ball stop (38) and check ball (39).

## Assembly

To assemble, perform **Disassembly** procedures in reverse. Tighten fasteners per stated torque specifications.

### Notice

Prevent damage to air piston packing, pump gland packing, and to help increase packing life, lubricate air cylinder and air piston rod before assembly.

Thread piston rod through gland packing when assembling pump.

Before tightening four valve seat screws (61), align valve slide and seat plate (58), slide valve gasket (56) and air valve casting (9) by placing a rod through the center hole.

Start all fasteners by hand to avoid stripping threads when reassembling.

## Repair

Repair is limited to replacement of listed service parts. Special procedures and tools are required. Contact Lincoln customer service, One Lincoln Way, St. Louis, MO 63120-1578, (314) 679-4200 for your nearest authorized service center.

When ordering replacement parts, list part number, description, model number and series letter.

### Service parts

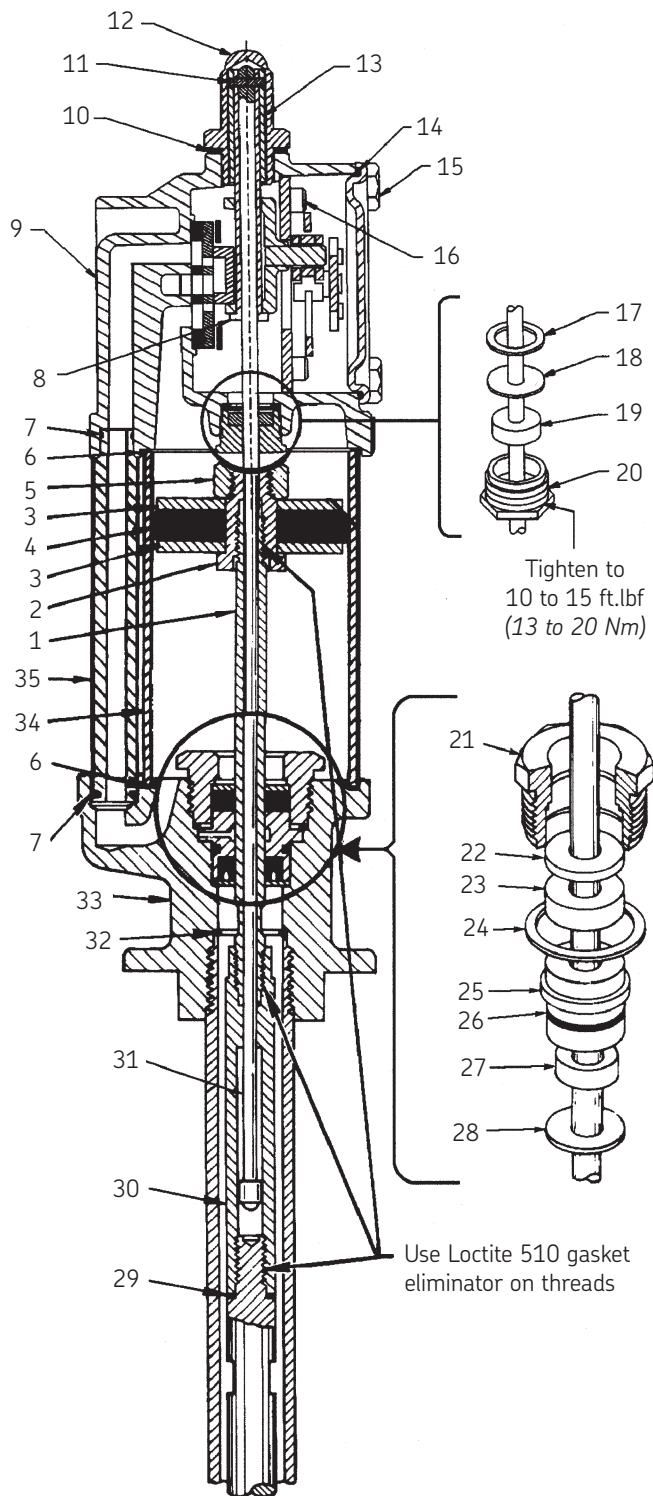

Service parts

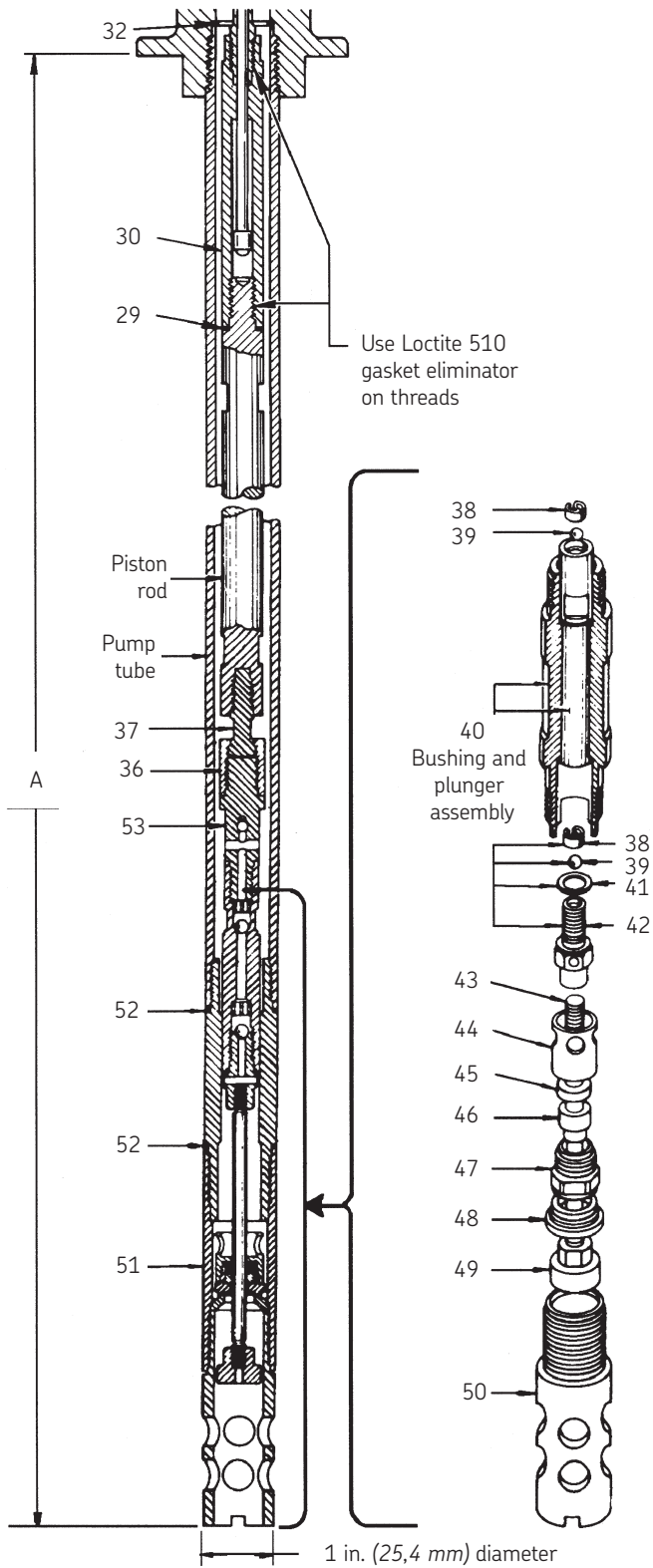

Service parts

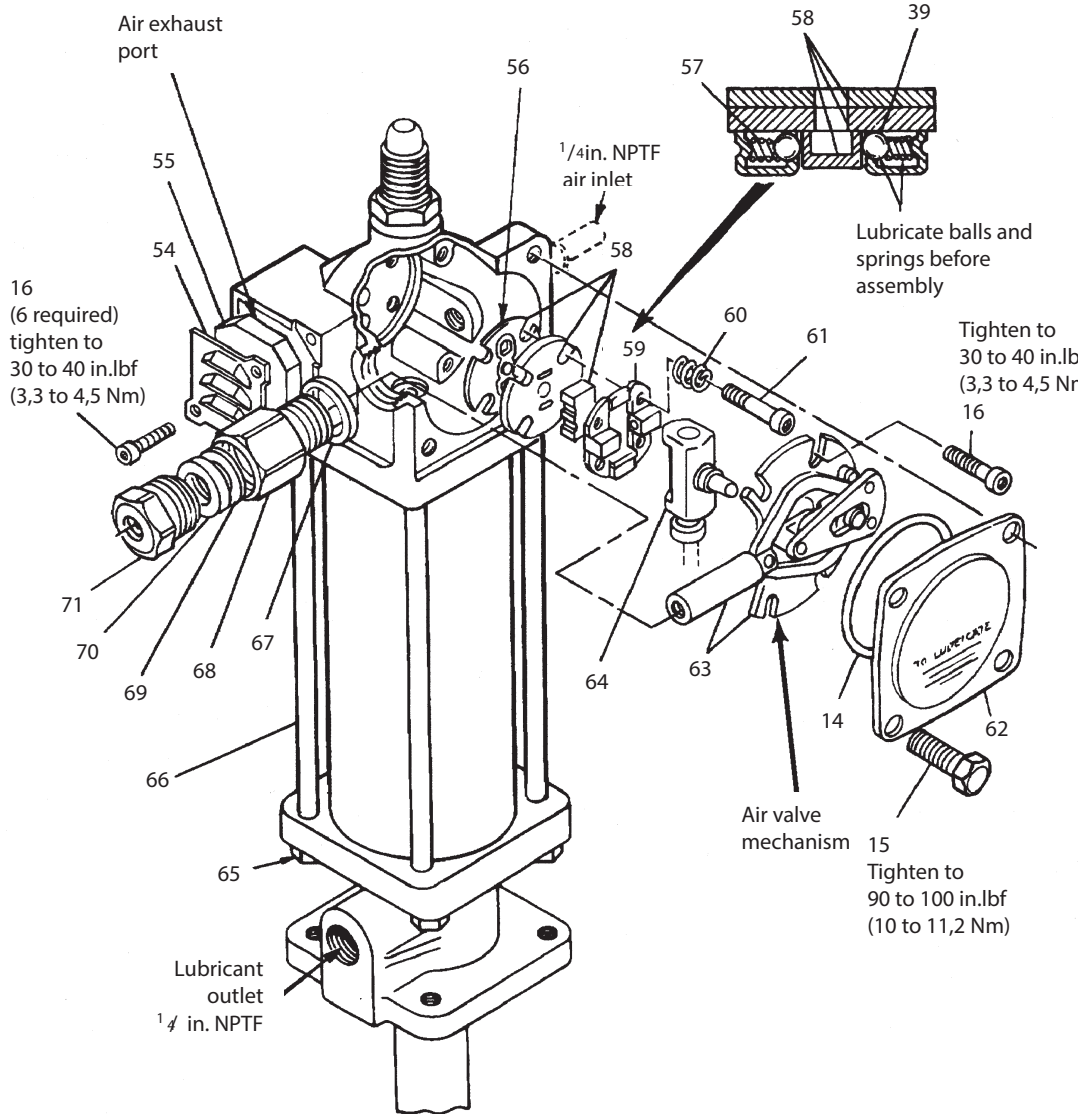

**!** Notice

Start fasteners by hand to avoid stripping threads when reassembling.

**Optional eyebolt kit**

(For hoisting purposes. Parts must be ordered separately)

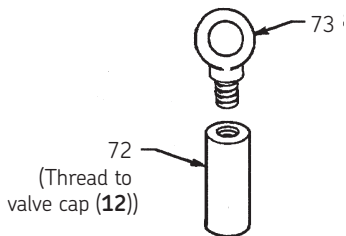

## To lubricate air valve mechanism

- 1 Disconnect air to pump.
- 2 Perform pressure relief procedure.
- 3 Remove four cover screws, cover plate and cover plate gasket.
- 4 Remove air valve casting from the pump and disassemble.
- 5 Clean or flush the air valve casting to remove any chips or other foreign particles.
- 6 Before replacing toggle assembly, pack cavity with grease using approximately 1 1/2 ounces of N.L.G.I. No. 1 (light grade) water repellent grease.
- 7 Replace cover plate gasket, cover plate and cover screws. Tighten to prevent air leaks.

- 8 Periodic inspection of parts at least once a year is advised.

**⚠ WARNING**

**Do not** disassemble or assemble pump with pressure applied to pump or system.

Relieve all pressure from system before and after use of pump.

Failure to comply may result in death or serious injury.



## Service parts list

Item no.	Description	Part no.	Qty.	Item no.	Description	Part no.	Qty.
1	Air motor piston rod	11340 <sup>1)</sup>	1	37	Coupling stud	11346	1
2	Air piston bolt	11329	1	38	Ball stop	57027	2
3	Air piston washer	48212	2	39	Ball	69102 <sup>1)3)</sup>	1
4	Air piston packing	34090 <sup>2)</sup>	1	40	Plunger and bushing assembly	90554	1
5	Air piston nut	11337	1	41	Check seat gasket	31047 <sup>1)3)</sup>	1
6	Air cylinder gasket	33014 <sup>1)</sup>	2	42	Check seat	11726 <sup>1)3)</sup>	1
7	O-ring	34368 <sup>1)</sup>	2	43	Plunger rod	11723 <sup>1)3)</sup>	1
8	Trip sleeve	11947	1	44	Check stop	11722	1
9	Air valve casting	237563	1	45	Priming check packing	35073 <sup>1)3)</sup>	1
10	Valve cap gasket	30011 <sup>1)</sup>	1	46	Check washer	11702 <sup>1)3)</sup>	1
11	Trip rod pin	11472 <sup>1)</sup>	1	47	Priming check	11721 <sup>1)3)</sup>	1
12	Valve cap	11470	1	48	Priming check seat	11725 <sup>1)3)</sup>	1
13	Trip rod collar	11471	1	49	Priming plunger	11724 <sup>1)3)</sup>	1
14	Cover gasket	34158 <sup>1)</sup>	1	50	Priming tube	239719	1
15	Valve cover screw	236868	4	51	Bushing extension	61273	1
16	Toggle plate screw	236869	6	52	Bushing gasket	31049	2
17	Gasket	33039 <sup>1)</sup>	1	53	Plunger adapter	11344	1
18	Packing washer	236616 <sup>1)2)</sup>	1	54	Muffler cover	236615	1
19	Trip rod packing	236835 <sup>1)2)</sup>	1	55	Muffler	236833	1
20	Trip rod packing nut	245425	1	56	Slide valve gasket	38162 <sup>1)</sup>	1
21	Gland packing nut	12333	1	57	Spring	56038 <sup>1)</sup>	2
22	Gland packing washer	48268	1	58	Valve slide and seat	83063	1
23	Gland packing	34180	1	59	Valve guide plate	45605	1
24	Gland gasket	31050 <sup>1)</sup>	1	60	Spring	55138	4
25	Gland packing spacer	14940	1	61	Valve seat bolt	236870	4
26	O-ring	34572 <sup>1)</sup>	1	62	Cover	236286	1
27	U-cup packing	38165 <sup>1)</sup>	1	63	Toggle plate	91331 <sup>2)</sup>	1
28	Gland packing washer	48213	1	64	Trip shoe	11475	1
29	Connector gasket	31048 <sup>1)</sup>	1	65	Tie rod nut	51009	4
30	Piston rod connector	11349	1	66	Tie rod	10294	4
31	Trip rod	90691 <sup>2)</sup>	1	67	Packing nut gasket	30003	1
32	Pump tube gasket	31054 <sup>1)</sup>	1	68	Packing nut	11904	1
33	Outlet body	40537	1	69	Plunger packing washer	48237	1
34	Air cylinder	61041 <sup>2)</sup>	1	70	Plunger packing	34110	1
35	Air passage tube	61502	1	71	Packing cap	11905	1
36	Coupling nut	11345	1	72	Extension adapter	236975	1
				73	Eye bolt	68531	1

<sup>1)</sup> Included in 83054 pump repair kit.

<sup>2)</sup> Recommended service part

<sup>3)</sup> Included in 83001 power pump tube repair kit.

# EC Declaration of Conformity in accordance with Machinery Directive 2006/42/EC, Annex II Part 1 A

The manufacturer Lincoln Industrial, One  
Lincoln Way, St. Louis, MO 63120-1578  
USA hereby declares that the machine

Designation: High-pressure air operated  
chassis pump 50:1

Type: 2 1/2 in. (63,5 mm) Model 82050,  
series "J".

Year of construction: see type identifica-  
tion plate complies with all basic require-  
ments of the following directives at the time  
when first being launched in the market.

Machinery directive 2006/42/EC  
and RoHS II 2011/65/EU

Applied standards DIN EN ISO  
12100:2011-3, DIN EN 809-1:2011,  
DIN EN 4414:2011-04.

In the case of modifications or alterations of  
the above mentioned machine not author-  
ized by the manufacturer validity of this EC  
declaration of conformity will cease. The  
person empowered to assemble the techni-  
cal documentation on behalf of the manu-  
facturer is the head of standardization; see  
EC-Representative's address.

EC-Representative  
SKF Lubrication Systems Germany GmbH  
Heinrich-Hertz-Str. 2-8  
DE - 69190 Walldorf

Manufacturer  
Lincoln Industrial, One Lincoln Way  
St. Louis, MO 63120-1578 USA

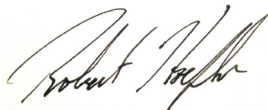

Robert Hoefler,  
Director Product Development /  
Product Engineering  
January 15, 2015

# Lincoln industrial standard warranty

## Limited warranty

Lincoln warrants the equipment manufactured and supplied by Lincoln to be free from defects in material and workmanship for a period of one (1) year following the date of purchase, excluding there from any special, extended, or limited warranty published by Lincoln. If equipment is determined to be defective during this warranty period, it will be repaired or replaced, within Lincoln's sole discretion, without charge.

This warranty is conditioned upon the determination of a Lincoln authorized representative that the equipment is defective. To obtain repair or replacement, you must ship the equipment, transportation charges prepaid, with proof of purchase to a Lincoln Authorized Warranty and Service Center within the warranty period.

This warranty is extended to the original retail purchaser only. This warranty does not apply to equipment damaged from accident, overload, abuse, misuse, negligence, faulty installation or abrasive or corrosive material, equipment that has been altered, or equipment repaired by anyone not authorized by Lincoln. This warranty applies only to equipment installed, operated and maintained in strict accordance with the written specifications and recommendations provided by Lincoln or its authorized field personnel.

**This warranty is exclusive and is in lieu of any other warranties, express or implied, including, but not limited to, the warranty of merchantability or warranty of fitness for a particular purpose. Warranty on items sold by Lincoln, but not manufactured by Lincoln are subject to the warranty consideration, if any, of their manufacturer (such as hoses, hydraulic and electric motors, electrical controllers, etc.) Assistance in making such warranty claims can be offered as required.**

In no event shall Lincoln be liable for incidental or consequential damages. Lincoln's liability for any claim for loss or damages arising out of the sale, resale or use of any Lincoln equipment shall in no event exceed the purchase price. Some jurisdictions do not allow the exclusion or limitation of incidental or consequential damages, therefore the above limitation or exclusion may not apply to you.

This warranty gives you specific legal rights. You may also have other rights that vary by jurisdiction.

Customers not located in the Western Hemisphere or East Asia: Please contact SKF Lubrication Systems, Germany, GmbH for your warranty rights.

## Lincoln Industrial Special limited warranties

### Special limited 2 year warranty SL-V series, single injectors – 85772, 85782, replacement injectors – 85771, 85781, and FlowMaster II

Lincoln warrants the SL-V Injector series and bare FlowMaster II "pump only" models to be free from defects in material and workmanship for two (2) years following the date of purchase. If an injector model (single or replacement) or "bare" FlowMaster II pump is determined to be defective by Lincoln, in its sole discretion, during this warranty period, it will be repaired or replaced, at Lincoln's discretion, without charge.

### Special limited 5 year warranty series 20, 25, 40 bare pumps, pmv bare pumps, heavy duty and 94000 series bare reels

Lincoln warrants series 20, 25, 40 bare pumps, PMV bare pumps, Heavy Duty (82206), Mini Bench (81133, 81323), and all 94000 LFR series (single arm and dual arm) bare reels to be free from defects in material and workmanship for five (5) years following the date of purchase. If equipment is determined by Lincoln, in its sole discretion, to be defective during the first year of the warranty period, it will be repaired or replaced at Lincoln's discretion, without charge. In years two (2) and three (3), the warranty on this equipment is limited to repair with Lincoln paying parts and labor only. In years four (4) and five (5), the warranty on this equipment is limited to repair with Lincoln paying for parts only.

### Special limited 5 year warranty limited oil meters, limited fluid control valves, aod (air-operated diaphragm pumps)

Lincoln warrants the 716 series Control Valves, 916 series Lube Meters, Electronic Lube Meters (980, 981, 982 series), our Universal Inline Digital Meters (814/817 series), and our AOD Pump offering to be free from defects in material and workmanship for five (5) years following the date of purchase. If either is determined to be defective by Lincoln, in its sole discretion, during the warranty period, they will be repaired or replaced, at Lincoln's discretion, without charge.

### Special DEF (diesel exhaust fluid) limited warranty

DEF products are warranted to be free from defects in material and workmanship for a period of one (1) year following the date of purchase. The following exceptions to the standard warranty period are in effect;

- 85700-30/85700-50 DEF hose reels (bare reel only), 277251/277252 AC DEF pumps, and 277256 and 277257 DEF meters are warranted for two (2) years from date of purchase,
- 85623 DEF AOD (air operated diaphragm) pumps are covered under the standard five (5) year AOD pump warranty.

If either is determined to be defective by Lincoln, in its sole discretion, during the warranty period, they will be repaired or replaced, at Lincoln's discretion, without charge.

### Lincoln Industrial contact information

To find Lincoln Industrial's nearest service center call the following number; customer service 314-679-4200 (international number 01-314-679-4200) or you may also use our website [www.lincolnindustrial.com](http://www.lincolnindustrial.com)

## The Power of Knowledge Engineering

Combining products, people, and application-specific knowledge, SKF delivers innovative solutions to equipment manufacturers and production facilities in every major industry worldwide. Having expertise in multiple competence areas supports SKF Life Cycle Management, a proven approach to improving equipment reliability, optimizing operational and energy efficiency and reducing total cost of ownership.

These competence areas include bearings and units, seals, lubrication systems, mechatronics, and a wide range of services, from 3-D computer modelling to cloud-based condition monitoring and asset management services.

SKF's global footprint provides SKF customers with uniform quality standards and worldwide product availability. Our local presence provides direct access to the experience, knowledge and ingenuity of SKF people.

© SKF is a registered trademark of the SKF Group.

© Lincoln is a registered trademark of Lincoln Industrial Corp.

© SKF Group 2015

The contents of this publication are the copyright of the publisher and may not be reproduced (even extracts) unless prior written permission is granted. Every care has been taken to ensure the accuracy of the information contained in this publication but no liability can be accepted for any loss or damage whether direct, indirect or consequential arising out of the use of the information contained herein.

SKF PUB LS/I4 15886 EN.R1 · July 2015 · Form 403510S

