

SPECIFICATIONS

Maximum working pressure	2000 p.s.i.
Material Inlet	3/4" NPT (Female)
Material outlet	3/4" NPT (Female)
Sheave width	5-1/2"
Sheave diameter	19-1/4"
Drum diameter	12-3/4"
Overall width	10"
Overall height	22-1/2"
Overall depth	21"

The owner/operator shall retain this manual for future reference to Important warnings, operating and maintenance instructions.

DESCRIPTION

The Model 84672 high flow hose reel is a spring operated unit designed to hold and retract upto 50 feet of 1/2" diameter hose. Larger hose diameters can be used with reduced hose length, see maximum hose capacity chart on page 2.

The reel is a heavy duty unit and designed for bus and truck lubrication or wherever extra heavy duty construction and longer length delivery hose is required. The reel can be installed as a single unit or in multiple configurations.

Reel features include a reel latch that automatically locks at desired positions as the hose is extended and releases with a short pull on the hose.

OWNER/OPERATOR RESPONSIBILITY

It is the owner/operator responsibility to properly use and maintain this equipment.

The instructions and warnings contained in this manual shall be read and understood by the owner/operator prior to operating this equipment.

If an owner/operator does not understand English, the contents of this manual shall be explained in the owner/operator native language to assure the owner/operator comprehends.

It is the owner/operator responsibility to maintain the legibility of all warning and instruction labels.



CAUTION

Failure to heed the following warnings including misuse, over pressurizing, modifying parts, using incompatible chemicals and fluids, or using worn or damaged parts, may result in equipment damage and/or serious personal injury, fire, explosion, or property damage.

Do not exceed the stated maximum working pressure of the reel or of the lowest rated component in your system.

Do not alter or modify any part of this equipment.

Do not operate this equipment with combustible gas.

Do not attempt to repair or disassemble the equipment while the system is pressurized.

Make sure all fluid connections are securely tightened before using this equipment.

Always read and follow the fluid manufacturer's recommendations regarding fluid compatibility, and the use of protective clothing and equipment.

Check all equipment regularly and repair or replace worn or damaged parts immediately.

Never point the dispensing valve at any part of the body or at another person.

Never try to stop or deflect material from dispensing valve or leading connection or component with your hand or body.

Always check equipment for proper operation before each use, making sure safety devices are in place and operating properly.

Always follow the pressure relief procedure after shutting off the pump, when checking or servicing any part of the system, and when installing, cleaning or changing any part of the system.

© Indicates change



WARNING

Systems which will be dispensing fluids under pressure may need to be protected by using a thermal relief kit, which will safely limit the pressures caused by thermal expansion. Please contact your local Lincoln distributor and refer to Service Page Section K5, Page 31 for more details. Failure to include thermal relief protection may cause damage not covered under Lincoln's warranty policy.

INSTALLATION

DELIVERY HOSE INSTALLATION (MAXIMUM SPRING TENSION)

NOTE: Maximum hose capacities are based on SAE specified hoses. Exceeding these capacities voids warranty. Refer to DELIVERY HOSE INSTALLATION for proper hose to reel assembly.

Maximum hose capacities (including hang down):		
3/4" I.D. air/water hose (SAE 100 R3)		40 ft.
1/2" I.D. Air/water hose (SAE 100 R6)		50 ft.
1/2" I.D. Oil hose (SAE 100 R3)	50 ft.	
3/4" I.D. Oil hose (SAE 100 R11)		30 ft.

For smoother operation during retraction and to increase hose life, de-tack hose by wiping entire hose length with a light lubricating oil before installing on reel. Assemble outlet adapter to hose and tighten securely. Use teflon tape on threads to prevent leaks. **See Figure (1).** Insert hose end with outlet adapter through roller outlet and secure to axle head with U-keeper. Make sure seal is installed correctly in axle before assembling.



CAUTION

To prevent damaging hose connections and/or components when pulling hose from reel, pull on the hose itself and not on the control valve or swivel. Do not pull or jerk on the hose when fully withdrawn from the reel.

From open side of reel, loop entire length of hose onto reel in a clockwise direction. Pull hose out through roller outlet to wind power spring. When hose is completely extended, latch reel to prevent it from unwinding. Continue to add loops of hose and pull out hose until power spring winds tight.

IMPORTANT INSTRUCTIONS

Perform the following instructions as stated to correctly set the power spring for maximum tension. Allow reel to retract two full revolutions and latch reel. Carefully unloop remaining hose from reel.



CAUTION

To avoid damaging reel components, always make sure hose clamp is properly installed.

Position hose clamp so that approximately 1/2 loop of hose remains on reel and latching does not occur when hose is fully extended. While holding hose, allow reel to retract hose until desired height from floor is obtained, then latch reel. Slide ball stop over free end of hose and position slightly below roller outlet. Tighten screws to secure ball stop to hose. Power spring is now set to maximum tension.

ADJUSTING SPRING TENSION



CAUTION

To prevent premature power spring failure, spring tension should be adjusted so that it requires at least two full turns of the reel sheave before the spring is wound tight.

Should less spring tension be desired, pull hose out from roller outlet to provide slack and latch reel. Unwind one loop of hose from reel. Pull excess hose out through roller outlet and unlatch reel to retract hose. Check tension and repeat above procedure until desired tension is obtained.

ATTACHING CONNECTING HOSES



CAUTION

To prevent damage to connecting hose when installing hose to reel, sufficient clearance must be provided from outside edge of sheave.

See Figure (2). Assemble connecting hose to swivel. Connect other end of connecting hose to material supply line source or connection.

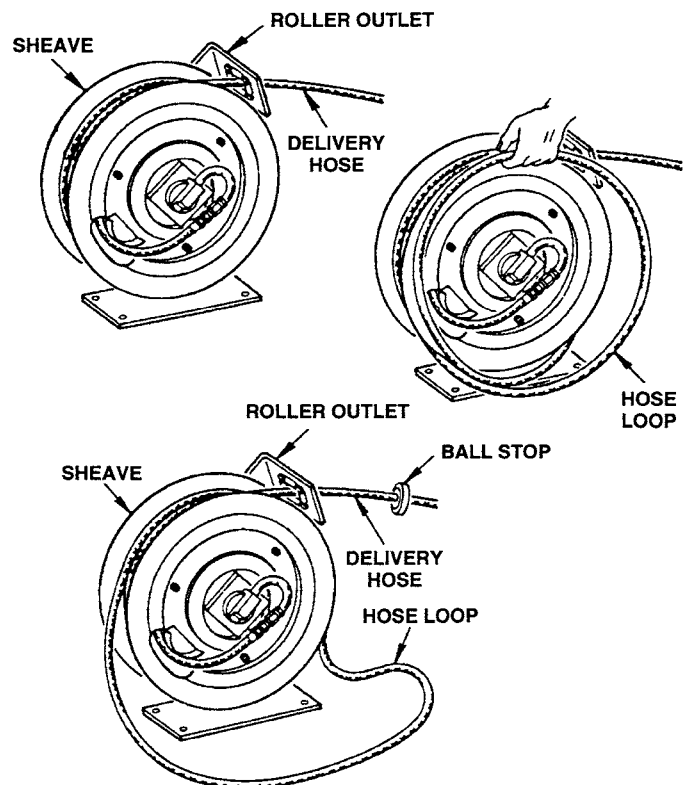

FIGURE (1) DELIVERY HOSE

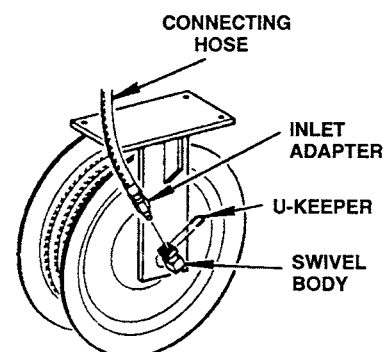

FIGURE (2) CONNECTING HOSE

REEL INSTALLATION AND ADJUSTMENT

See Figure (3). The guide arm may be positioned in 22-1/2 degree increments as shown. For ease of operation and increased hose life, the guide arm should be positioned to minimize hose strain as the delivery hose is pulled through the roller outlet.

Three studs must be used to securely attach the guide arm. It may be necessary to change the position of the hex head screw and one stud in order to obtain the desired guide arm position.

The hose clamp must be relocated if the guide arm is in position B or C. Refer to SERVICE PARTS for hose clamp location.

SAFETY INFORMATION

Read and understand all warnings, cautions and instructions before operating this equipment. Extreme caution should be used when operating this equipment as personal injury and/or property damage can result from equipment misuse. Adequate personal protection is recommended to prevent splashing of material on the skin or in the eyes. ALWAYS disconnect air coupler from pump when the pump is not being used.

PRESSURE RELIEF PROCEDURE

Always perform this procedure when the pump is shut off and before checking, servicing, installing, cleaning or repairing any part of this system.

Perform the following procedure:

- A. Disconnect the air supply to the pump.
- B. Point the dispensing valve away from yourself and others.
- C. Open the dispensing valve into an appropriate container until the pressure is relieved.

If the above procedure does not relieve the pressure, the dispensing valve or hose may be restricted. To relieve the pressure, very slowly loosen the hose end coupling. Then loosen completely and clear the dispensing valve and/or hose.

INSPECTION

Prior to operation or maintenance a visual inspection shall be made. Check reel system for leaks, worn or missing parts. Any reel that appears to be damaged in any way, is badly worn or operates abnormally shall be removed from use until repairs are made. Contact factory authorized service center for repairs.

If overpressurizing of the equipment is believed to have occurred, contact a factory authorized service center for inspection of the reel.

Annual inspection by a factory authorized service center is recommended.

DISASSEMBLY

To disassemble, perform ASSEMBLY procedures in reverse.

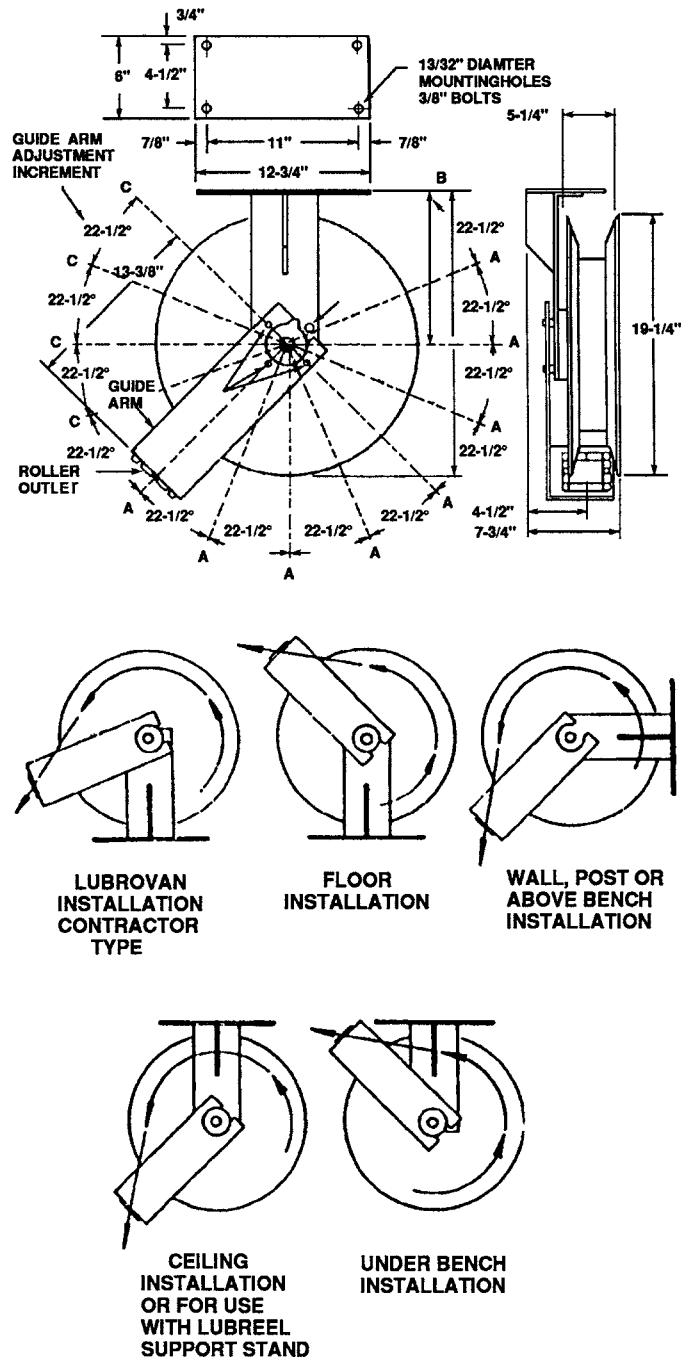
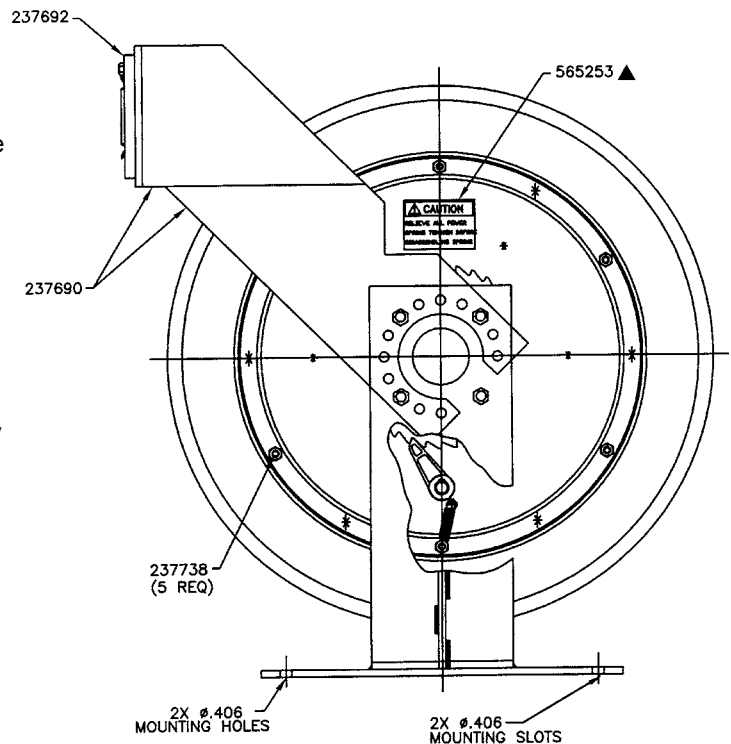
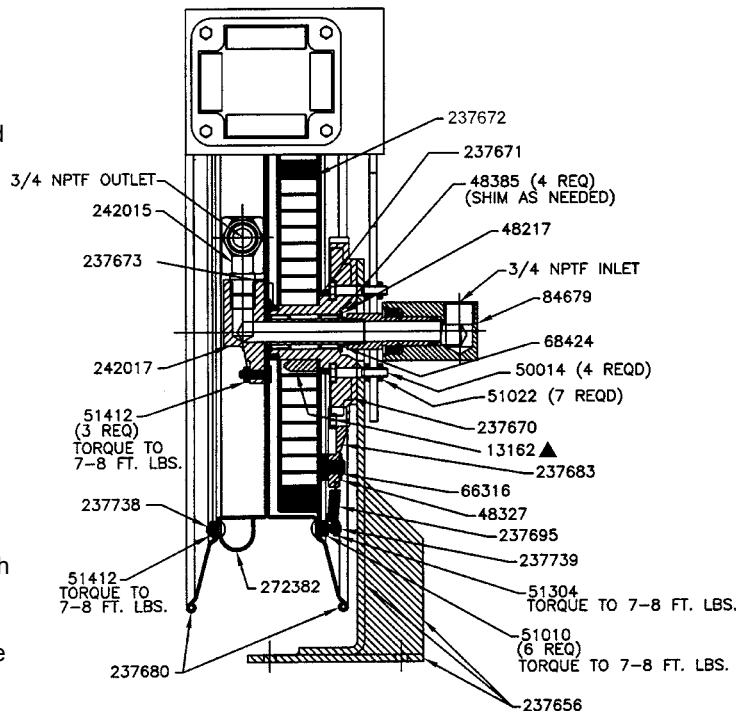

FIGURE (3) REEL INSTALLATION AND ADJUSTMENT

ASSEMBLY

Assemble reel as follows. Refer to SERVICE PARTS for part numbers and location.

- A. Assemble arbor and ratchet casting (237670) to support assembly (237656) with four hex head screws (50014) and four hex nuts (51022).
- B. Lubricate V-ring seal (237671) and place on arbor and ratchet casting (237670) with lip facing away from arbor ratchet.
- C. Assemble power spring assembly (237672) onto arbor and ratchet casting (237670) until spring canister bottoms on arbors shoulder.
- D. Lubricate V-ring seal (237673) and assemble onto arbor and ratchet casting (237670) with lip facing toward spring canister.
- E. Assemble axle (242017) to sheave assembly (237680) with three nuts (51412).
- F. Assemble axle and sheave assembly to reel by sliding axle (242017) through bearings in the arbor and ratchet casting (237670). Secure with washer (48217) and TRU-ARC (68424). Shim as required using shims (48385) between washer (48217) and arbor and ratchet casting (237670) to eliminate axle end play.
- G. Rotate sheave assembly (237680) and align six mounting holes with mating holes in power spring canister (237672). Secure with five carriage bolts (237738), carriage bolt (237739) and six nuts (51412).
NOTE: The carriage bolt (237739) is assembled in hole adjacent to pawl pin.
- H. Assemble roller outlet arm assembly (237690) on bolts (50014) and secure using three nuts (51022).
- I. Assemble roller outlet assembly (237692) to roller outlet arm assembly (237690) by snapping into stamped out contour in roller arm. Make certain that snaplocks are firmly seated after assembling. Install (50033) hex head screws through roller outlet. Secure with nut (51304).
- J. Assemble swivel assembly (84679) onto axle (242017) and tighten.
- K. Assemble swivel adapter (242015) into axle (242017).
- L. Assemble hose clamp (272382) to sheave assembly (237680) with carriage bolt (237738). Secure with nut (51010).
- M. Assemble latch pawl (237683) to pawl pin on power spring assembly (237672) and secure with washer (48327) and TRUARC (66316).
- N. Assemble extension spring (237695) to latch pawl (237683) and carriage bolt (237739). Secure with locknut (51304).



▲ 13162 and 565253 are part of 237672

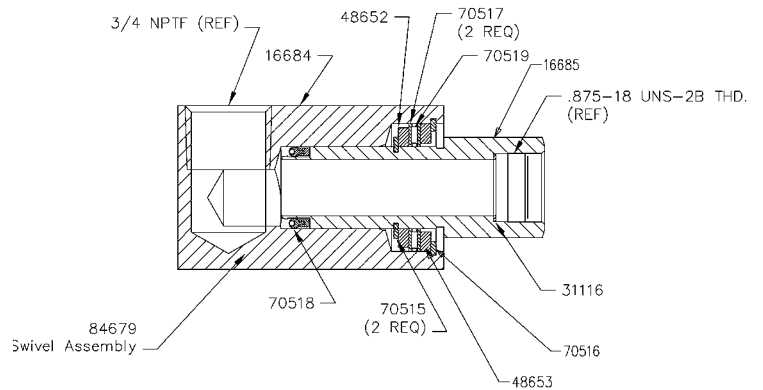
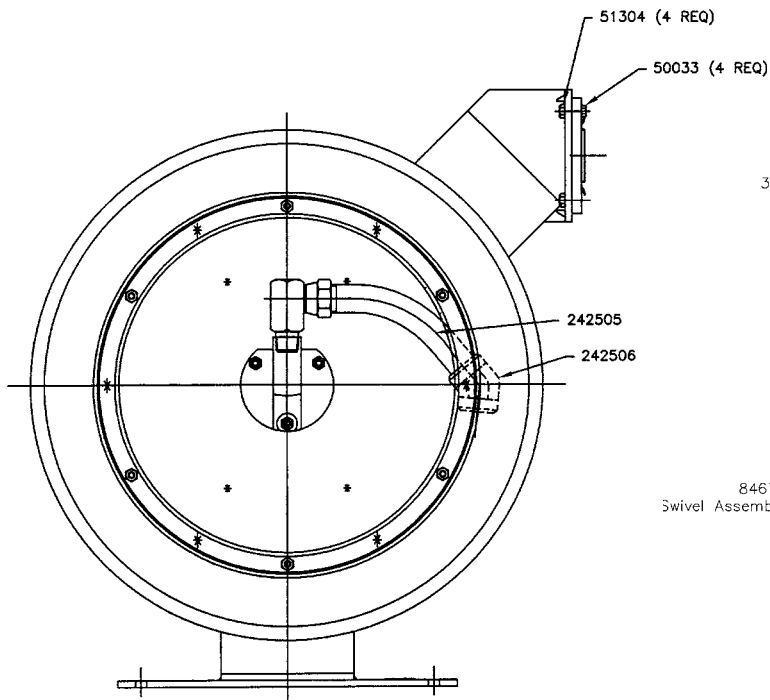

84679 SWIVEL ASSEMBLY
 ASSEMBLE TO AXLE WITH LOCTITE 242
 TORQUE TO 50 FT-LBS

SERVICE PARTS

PART	QTY	DESCRIPTION	PART	QTY	DESCRIPTION
48217	1	Washer	237672	1	Power spring assembly
48327	1	Washer	237673	1	V-ring seal
48385	4	Shim washer	237680	1	Sheave assembly
50014	4	Hex head screw	237683	1	Latch pawl
50033	4	Hex head screw	237690	1	Roller outlet arm assembly
51022	7	Hex nut	237692	1	Roller outlet assembly
51304	5	Locknut	237695	1	Extension spring
51412	10	Hex nut	237738	6	Carriage bolt
66316	1	Tru-arc	237739	1	Carriage bolt
68424	1	Tru-arc	242015	1	Swivel adapter
84679	1	Swivel assembly	242017	1	Axle
237656	1	Support assembly	242505	1	3/4" NPTF Nipple
237670	1	Arbor and ratchet casting	242506	1	3/4" NPTF Elbow (45)
237671	1	V-ring seal	272382	1	Hose clamp

REPAIR

Repair is limited to replacement of listed service parts. Special procedures and tools are required. Contact Lincoln Customer Service, One Lincoln Way, St. Louis, MO 63120-1578, (314) 679-4200 for your nearest authorized service center.

When ordering replacement parts, list:
 Part number, description, model number and series letter.

Lincoln Industrial Standard Warranty

LIMITED WARRANTY

Lincoln warrants the equipment manufactured and supplied by Lincoln to be free from defects in material and workmanship for a period of one (1) year following the date of purchase, excluding therefrom any special, extended, or limited warranty published by Lincoln. If equipment is determined to be defective during this warranty period, it will be repaired or replaced, within Lincoln's sole discretion, without charge.

This warranty is conditioned upon the determination of a Lincoln authorized representative that the equipment is defective. To obtain repair or replacement, you must ship the equipment, transportation charges prepaid, with proof of purchase to a Lincoln Authorized Warranty and Service Center within the warranty period.

This warranty is extended to the original retail purchaser only. This warranty does not apply to equipment damaged from accident, overload, abuse, misuse, negligence, faulty installation or abrasive or corrosive material, equipment that has been altered, or equipment repaired by anyone not authorized by Lincoln. This warranty applies only to equipment installed, operated and maintained in strict accordance with the written specifications and recommendations provided by Lincoln or its authorized field personnel.

THIS WARRANTY IS EXCLUSIVE AND IS IN LIEU OF ANY OTHER WARRANTIES, EXPRESS OR IMPLIED, INCLUDING, BUT NOT LIMITED TO, THE WARRANTY OF MERCHANTABILITY OR WARRANTY OF FITNESS FOR A PARTICULAR PURPOSE.

In no event shall Lincoln be liable for incidental or consequential damages. Lincoln's liability for any claim for loss or damages arising out of the sale, resale or use of any Lincoln equipment shall in no event exceed the purchase price. Some jurisdictions do not allow the exclusion or limitation of incidental or consequential damages, therefore the above limitation or exclusion may not apply to you.

This warranty gives you specific legal rights. You may also have other rights that vary by jurisdiction.

Customers not located in the Western Hemisphere or East Asia: Please contact Lincoln GmbH & Co. KG, Walldorf, Germany, for your warranty rights.

Lincoln Industrial Special Limited Warranties

SPECIAL LIMITED 2 YEAR WARRANTY-

SL-V Series, Single Injectors-85772, 85782, and Replacement Injectors-85771, 85781

Lincoln warrants the SL-V Injector series to be free from defects in material and workmanship for two (2) years following the date of purchase. If an injector model (single or replacement) is determined to be defective by Lincoln, in its sole discretion, during this warranty period, it will be repaired or replaced, at Lincoln's discretion, without charge.

SPECIAL LIMITED 5 YEAR WARRANTY-

Series 20, 25, 40 Bare Pumps, PMV Bare Pumps, Heavy Duty and 94000 Series Bare Reels

Lincoln warrants series 20, 25, 40 bare pumps, PMV bare pumps, Heavy Duty (82206), Mini Bench (81133, 81323), and 94000 LFR series (94100, 94300, 94500) bare reels to be free from defects in material and workmanship for five (5) years following the date of purchase. If equipment is determined by Lincoln, in its sole discretion, to be defective during the first year of the warranty period, it will be repaired or replaced at Lincoln's discretion, without charge. In years two (2) and three (3), the warranty on this equipment is limited to repair with Lincoln paying parts and labor only. In years four (4) and five (5), the warranty on this equipment is limited to repair with Lincoln paying for parts only.

SPECIAL LIMITED 5 YEAR WARRANTY-

LFM Series Oil Meters (Lincoln Fluid Meter), LFV (Lincoln Fluid Valves), AOD (Air-Operated Diaphragm Pumps)-

Lincoln warrants the LFM meter series (908/912 series), the Lincoln Fluid valve (708/712 series), our Universal Inline Digital Meters (812/813 series), and our AOD Pump offering to be free from defects in material and workmanship for five (5) years following the date of purchase. If either is determined to be defective by Lincoln, in its sole discretion, during the warranty period, they will be repaired or replaced, at Lincoln's discretion, without charge.

Lincoln Industrial Contact Information

To find Lincoln Industrial's Nearest Service Center

Call one of the following numbers, you may also use our Website

Customer Service 314-679-4200
Website lincolnindustrial.com

Americas:
One Lincoln Way
St. Louis, MO 63120-1578
USA
Phone +1.314.679.4200
Fax +1.800.424.5359

Europe/Africa:
Heinrich-Hertz-Str 2-8
D-69183 Walldorf
Germany
Phone +49.6227.33.0
Fax +49.6227.33.259

Asia/Pacific:
No. 3 Tampines Central 1
#04-05, Abacus Plaza.
Singapore 529540
Tel +65.6588.0188
Fax +65.6588.3438

© Copyright 2010
Printed in USA

Web site:
www.lincolnindustrial.com