

Fire-Ball® 300, 50:1

Air-Powered Grease Pumps and Packages

Features and Benefits

- Priming piston pump in combination with the appropriate feeding technology provides positive pump feeding, even with viscous and/or tacky greases
- Non-corrosive air motor design for long life
- Double-acting pump ensures smooth fluid flow
- Robust grease inlet cage withstands the most abusive handling

Typical Applications

- Medium pressure, low to medium volume grease dispense
- Automotive dealerships
- Heavy-duty dealerships
- Fast lube and service centers
- Fleet service facilities
- Lube trucks
- Mining
- In-plant

Typical Fluids Handled

- Grease up to NLGI #2

Technical Specifications

Continuous-Duty Flow Rate	1.19 lb/min. (.54 kg/min.)
Maximum Fluid Pressure	8400 psi (580 bar)
Air Motor Effective Diameter	3 in (76.2 cm)
Operating Range	30-140 psi (3.0-9.7 bar)
Approximate Air Use	22.8 cfm @ 100 psi (7 bar)
Wetted Materials	CS, Delrin®, Buna-N, Polyurethane
Air Inlet Port Size	3/8 in npt(f)
Material Inlet	Slotted
Material Outlet.....	1/4 in npt(f)
Line Length‡	Up to 250 ft (76.2 m)
Dispense Points	1 to 2
Annual Usage	Up to 10,000 lb (4,535 kg)

Ordering Information

Fire-Ball 300 50:1 Pumps	
239877	35 lb or 70 lb (16 kg or 32 kg) Grease Pump - 50:1
239887	120 lb (55 kg) Grease Pump - 50:1
239888	400 lb (180 kg) Grease Pump - 50:1

Pump Performance

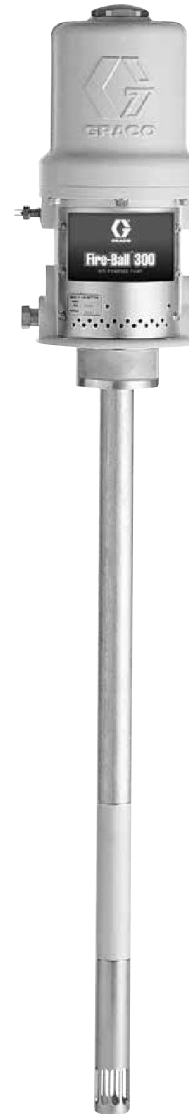
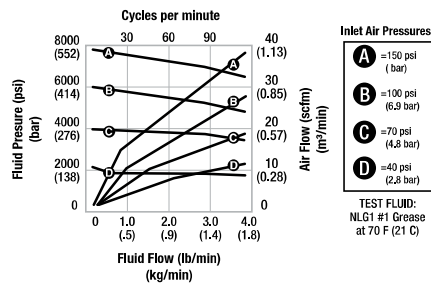

Air-Powered Grease Pumps and Packages

‡ Consult your local authorized Graco representative for line or pipe sizing

Fire-Ball® Grease Pump Packages

Air-Powered Grease Pumps and Packages

Fire-Ball® 300, 50:1 35-70 lb (16-32 kg) Grease Pumps and Packages

	Portable Pail Dispenser	Stationary Pail Dispenser	Cart-Mounted Pail Dispenser	Cart-Mounted Pail Topper
Container Size	35 lb (16 kg)	35 lb or 70 lb (16 kg or 32 kg)	35 lb or 70 lb (16 kg or 32 kg)	35 lb (16 kg)
Package No.	222069*	225827*	225773*	226012*
Metered Package**	245694	—	245695	—
Pump No.	239877			
Dispense Kit	222070			
Fluid Hose	12 ft x 1/4 in (3.7 m x 6.4 mm)			
Follower Plate	24F901	†	†	—
Cover	222059	24R350		—
Holster	—	203976		
Container	—	204134	204134	—
Cart	—	—	203650	
Elevator	—	—	—	203664
Inductor Plate	—	—	—	204351
Instruction Manual	307878			

*Use 3/8 in (9.5 mm) air regulator 109075; must be ordered separately **Metered grease package includes 233807 Accu-Shot instead of 242056 Pro-Shot. †Order follower plate 220653 for 35 lb (16 kg) containers, and follower plate 220654 for 70 lb (32 kg) containers; must be ordered separately



Fire-Ball® 300, 50:1 Packages For 120 lb (55 kg) Containers

	Portable with Caster Base	Portable with Two-Wheel Cart	Portable with Heavy-Duty Cart	Stationary Supply	Stationary Supply Topper-Inductor
Container Size lb (kg)	120 (55)	120 (55)	120 (55)	120 (55)	120 (55)
Package Number	225006 *	225026 *	222245 *	225014 *	222073 *
Metered Package	—	245696 **	—	—	—
Pump Only	239887	239887	239887	239887	239887
Dispense Kits	222070	222070	222383	222072	-
Fluid Hose	12 ft x 1/4 in (3.7 m x 6.4 mm)	—	25 ft x 1/4 in (7.6 m x 6.4 mm)	6 ft x 1/4 in (1.8 m x 6.4 mm)	6 ft x 1/4 in (1.8 m x 6.4 mm)
Air Hose	—	—	—	6 ft x 3/8 in (1.8 m x 9.5 mm)	6 ft x 3/8 in (1.8 m x 9.5 mm)
Follower Plate	24F902	24F902	24F902	24F902	—
Cover	24R350	24R350	222060	24R350	—
Holster	203976	203976	—	—	—
Caster Base	203622	—	—	—	—
Cart	—	203650	222243	—	—
Elevator	—	—	—	—	204121
Pump Support	—	—	—	—	222074†
Hold Down Kit	—	—	222061	—	—
Instruction Manual	307878	307878	307878	307880	306523

* Use 3/8 in (9.5 mm) air regulator 109075; must be ordered separately ** Metered grease package includes 233807 Accu-Shot instead of 242056 Pro-Shot † Pump support assembly includes dust cover, base, inductor plate and 6 ft (1.8 m) fluid and air hose

Fire-Ball® Lube Truck Oil and Grease Packages

Air-Powered Specialty Pumps and Packages

Oil Package Selection and Ordering Information

	Fire-Ball 300 Cover-Mounted Package	Fire-Ball 300 Cover-Mounted Package	Fire-Ball 300 Bung-Mounted Package	Fire-Ball 425 Cover-Mounted Package	Fire-Ball 425 Bung-Mounted Package
Ratio	5:1			10:1	
Container Size	16 gal (60 l) Open-head	55 gal (200 l) Closed-head*			55 gal (200 l) Closed-head*
Package Number	222086	206655	204264	206656	222067
Pump Only	203872	203857	204254	222065	222095
Hose/Fitting Kit	222063			222066	
Hose Length	6 ft (1.8 m)	6 ft (1.8 m)	6 ft (1.8 m)	6 ft (1.8 m)	6 ft (1.8 m)
Air Regulator	(1)	(1)	(1)	(2)	(2)
Hold-Down Kit	222061	207361			
Drum Cover	222060	207367	-	207367 ⁽³⁾	-
Bung Adapter	-	-	204076 (2.140 in Dia.)	-	224579 (2.159 in Dia.)
Pump Clamp	-	-	204095	-	204095
Instruction Manual	307883				

* For closed-head drums, pump mounts off-center on drum cover. Pump draws through standard 2 npt bung opening and is equipped with grommet for rain-tight seal to the drum cover.

⁽¹⁾ Order 3/8 in (9.5 mm) air regulator and gauge separately, (109075).

⁽²⁾ Order 1/2 in (12.7 mm) air regulator (104266) and gauge (100960) separately.

⁽³⁾ Off set drum cover

Grease Package Selection and Ordering Information

	Fire-Ball 300 Cover-Mounted Package	Fire-Ball 300 Cover-Mounted Package	Fire-Ball 425 Cover-Mounted Package	Fire-Ball 425 Cover-Mounted Package	Fire-Ball 425 Cover-Mounted Package	Fire-Ball 425 Cover-Mounted Package
Ratio	50:1				75:1	
Container Size	120 lb (55 kg) Open-head	400 lb (180kg) Open-head	120 lb (55 kg) Open-head	400 lb (180 kg) Open-head	120 lb (55 kg) Open-head	400 lb (180 kg) Open-head
Package Number	222085	222071	223107	222075	243817	243818
Pump Only	239887	239888	205394	205395	239729	239730
Hose/Fitting Kit	222072			222076		
Hose Length	6 ft (1.8 m)					
Air Regulator	*			**		
Hold-Down Kit	222061	207361	222061	207361	222061	207361
Drum Cover	222060	207366	222060	207366	222060	207366
Follower Plate	220654	223845	223344	223846	223344	223846
Instruction Manual	307880					

* Order 3/8 in (9.5 mm) air regulator and gauge separately, (109075).

** Order 1/2 in (12.7 mm) air regulator (104266) and gauge (100960).

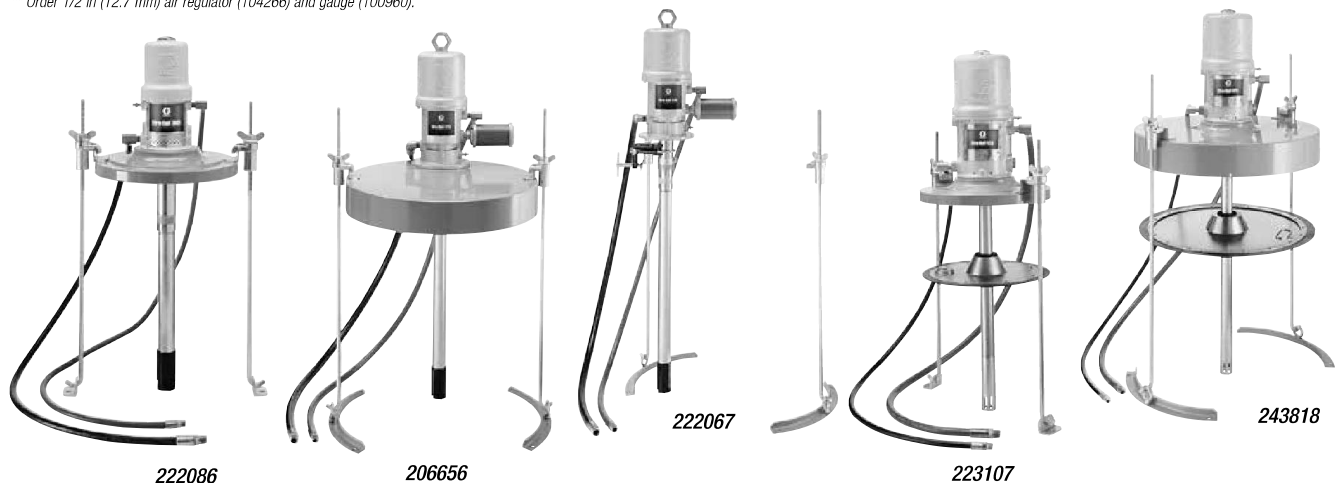

222086

206656

222067

223107

243818