



# 25 GPM (94 L/min) 12V & 24V (dc) Fuel Transfer Pump

**Models: V25-012PX, V25-012MD, V25-012AD,  
V25-024PX, V25-024MD, V25-024AD  
(PATENT-PENDING)**

**Thank you for choosing a Great Plains Industries product, and congratulations on your purchase!**

**Headquartered in the heartland of the U.S., GPI strives for integrity, innovation, continuous improvement, and dependability—values you will immediately recognize when using our products.**

**The maintenance policies and procedures outlined in this manual emphasize our commitment to safety and our dedication to you as a customer. By working together, we can ensure years of reliable, quality service.**

*Please save these instructions for future reference. Read carefully before attempting to assemble, install, operate or maintain the product described.*

*Protect yourself and others by observing all safety information. Failure to comply with instructions could result in personal injury and/or property damage.*

*Please refer to back cover for information regarding this product's warranty and other important information.*

**DO NOT RETURN THIS PRODUCT TO THE STORE!**

*Please contact Great Plains Industries, Inc. before returning any product. If you are missing parts, or experience problems with your installation, contact our Customer Support Department. We will be happy to assist you.*

**Call: 800-835-0113 or 316-686-7361**

**Email: [gpisales@gplains.com](mailto:gpisales@gplains.com)**

**Website: [gpi.net](http://gpi.net)**

**SAVE FOR YOUR RECORDS**

**Model #:** \_\_\_\_\_

**Serial #:** \_\_\_\_\_

**Purchase Date:** \_\_\_\_\_

## BEFORE YOU BEGIN

### Fueling Requirements

- All pump models in this manual are designed, tested, and approved for use with gasoline blends (up to E15), diesel fuel blends (up to B20) and kerosene. In addition, models V25-012PX and V25-024PX are approved for use with aviation gasoline (AVGAS 100LL) and kerosene grade (Jet A). Please take all due precautions when handling these flammable liquids.
- Do not use this pump for dispensing any fluids other than those for which it was designed. To do so may damage the pumps components and will void the warranty.



### Power Source Requirements

- Pump models V25-012PX, V25-012MD, and V25-012AD are to be connected to 12V (dc); Do not attempt connection of any pump to a 24V (dc), 115V (ac) or 230V (ac) power source.
- Pump models V25-024PX, V25-024MD, and V25-024AD are to be connected to 24V (dc); Do not attempt connection of any pump to a 12V (dc), 115V (ac) or 230V (ac) power source.



### Tools Needed

- Adjustable Wrench, Pipe Wrench, Pliers, Utility Knife, Wire Crimper/Stripper, and Metric Hex Wrenches (Hex Key) (4 & 5 mm - Included)

## UNPACKING



### Contents

Model	Lockable Nozzle Holder	Modular Fitting & Hardware	18 FT Power Cord	18 FT Dispensing Hose	Adjustable Suction Pipe	Diesel Shutoff Nozzle
V25-012PX	X	X	N/A	N/A	N/A	N/A
V25-012MD	X	X	X	X	X	Manual
V25-012AD	X	X	X	X	X	Automatic
V25-024PX	X	X	N/A	N/A	N/A	N/A
V25-024MD	X	X	X	X	X	Manual
V25-024AD	X	X	X	X	X	Automatic

### Inspect

- After unpacking the unit, inspect carefully for any damage that may have occurred during transit. Check for loose, missing or damaged parts. Shipping damage claims must be filed with carrier.
- Review General Safety Instructions and all Caution, Warning, and Danger statements as shown.



## GENERAL SAFETY INSTRUCTIONS

**IMPORTANT:** It is your responsibility to:

- Know and follow applicable national, state and local safety codes pertaining to installing and operating electrical equipment for use with flammable liquids.
- Know and follow all safety precautions when handling petroleum fuels.
- Ensure that all equipment operators have access to adequate instructions concerning safe operating and maintenance procedures.

Observe all safety precautions concerning safe handling of petroleum fuels

### SYMBOLS



Description of imminent hazard and failure to avoid hazard will result in death.



Description of hazard and possible resulting injuries or death.



Description of hazard and possible resulting injuries.



Warning of general danger



Warning of electric shock



Warning of hot surface



Read the operating manual and safety instructions



Disconnect power for maintenance and inspection



Smoking, open flames, fires, and open ignition sources are prohibited in the vicinity of this product.

SEE OWNER'S MANUAL FOR DETAILS

VOIR LE MANUEL DU PROPRIÉTAIRE POUR PLUS DE DÉTAILS

VEA EL MANUAL DEL PROPIETARIO PARA DETALLES

VEJA O MANUAL DO PROPRIETARIO PARA DETALHES

gpi.net/my-pump

## GENERAL SAFETY INSTRUCTIONS (CONTINUED)

### SAFETY WARNINGS

#### **⚠ DANGER**

To prevent physical injury or property damage, observe precautions against fire or explosion when dispensing fuel. Do not operate the system in the presence of any source of ignition including running or hot engines, lighted tobacco products, gas or electric heaters, or any type of electronic device. A spark can ignite fuel vapors.

#### **⚠ DANGER**

Observe precautions against electrical shock when operating the system. Serious or fatal shock can result from operating electrical equipment in damp or wet locations.

#### **⚠ DANGER**

Observe precautions against electrical shock when servicing the pump. Always disconnect power before repairing or servicing. Never apply electrical power to the system when any of the cover plates are removed.

#### **⚠ WARNING**

To ensure safe operation, all fuel transfer systems must be properly grounded. Proper grounding means a continuous metal-to-metal contact from one component to the next, including tank, tank mount, pump, meter, filter, hose and nozzle. Care should be taken to ensure proper grounding during initial installation and after any service or repair procedures. For your safety, please take a moment to review the warnings below.

#### **⚠ WARNING**

Inspect external pump wiring regularly to make sure it is correctly attached to the battery. To avoid electrical shock, use extra care when connecting the pump to power.

#### **⚠ WARNING**

Avoid prolonged skin contact with petroleum fuels. Use protective goggles, gloves and aprons in case of splashing or spills. Change saturated clothing and wash skin promptly with soap and water.

#### **⚠ WARNING**

All wetted connections should be sealed with appropriate sealant, thread tape, O-rings, and securely fastened. Leaking fuel may cause the potential for fire and explosion.

#### **⚠ WARNING**

PUMP MODELS THAT MAY BE USED IN AVIATION REFUELING (PO/PX MODELS) ARE NOT SUPPLIED WITH APPROPRIATE HOSE, NOZZLE, AND SUCTION PIPE. THESE ITEMS MUST MEET NFPA 407 GUIDELINES.

*For ground-based refueling only. Do not use in or on the aircraft. For use with aviation gasoline (AVGAS 100LL) and kerosene grade (Jet A). User should consult NFPA 407 Standard for Aircraft Fuel Servicing for safety requirements during ground fuel servicing of aircraft using liquid petroleum fuels. This product has no actual or implied compliance with this standard.*

#### **⚠ CAUTION**

If using solvent to clean pump components or tank, observe the solvent manufacturer's recommendations for safe use and disposal.

## SPECIFICATIONS

	V25-012PX	V25-012MD	V25-012AD	V25-024PX	V25-024MD	V25-024AD
Housing Material	Cast Iron					
Pump Rate	25 GPM (94 L/min)					
Duty Cycle	Intermittent, 30 minute ON, 30 minute OFF					
Suction Lift	Up to 15 ft. (4.5 m)					
Operating Temperature	-20 °F to 125 °F (-29 °C to 52 °C)					
XTS Operating Temperature	Extreme Temperature Series pumps are capable of operation down to -40 °F (-40 °C). Any pump operation below -20 °F (-29 °C) has not been evaluated by any regulating agency.					
Max. Surface Temperature	320 °F (160 °C)					
Operating Pressure	20 PSI (1.37 bar)					
Input	12V (dc)			24V (dc)		
Current Draw	35 amps			18 amps		
Motor	1620 RPM, .41 hp					
<b>Motor Approval</b>						
cULus Listed, Class I Div 1, IECEx/ATEX Zone 1	YES	NO		YES	NO	
cULus Listed, Class I Div 2	NO	YES		NO	YES	
Motor Protection	40 amp circuit breaker			20 amp circuit breaker		
Cord	N/A	18 ft. (5.5 m) of 10 ga.		N/A	18 ft. (5.5 m) of 10 ga	
Fuse	40 amp			20 amp		
Tank Adapter	2 in. NPT					
Inlet	1 in. NPT					
Outlet	1 in. NPT					
Hose Type	N/A	Buna-N Electrically Conductive Discharge Hose with Static Wire		N/A	Buna-N Electrically Conductive Discharge Hose with Static Wire	
Hose Size	N/A	1 in. x 18 ft. (5.5 m)		N/A	1 in. x 18 ft. (5.5 m)	
Nozzle	N/A	1 in. Manual Diesel	1 in. Auto Diesel	N/A	1 in. Manual Diesel	1 in. Auto Diesel

## SPECIFICATIONS (CONTINUED)

Dimensions	V25-012PX, V25-012MD, V25-012AD
A. Pump Assy Width	10.86 in. (27.58 cm)
B. Pump Assy Height	11.38 in. (28.90 cm)
C. Pump Assy Depth	12.11 in. (30.75 cm)
D. Pump Housing Depth	10.14 in. (25.75 cm)

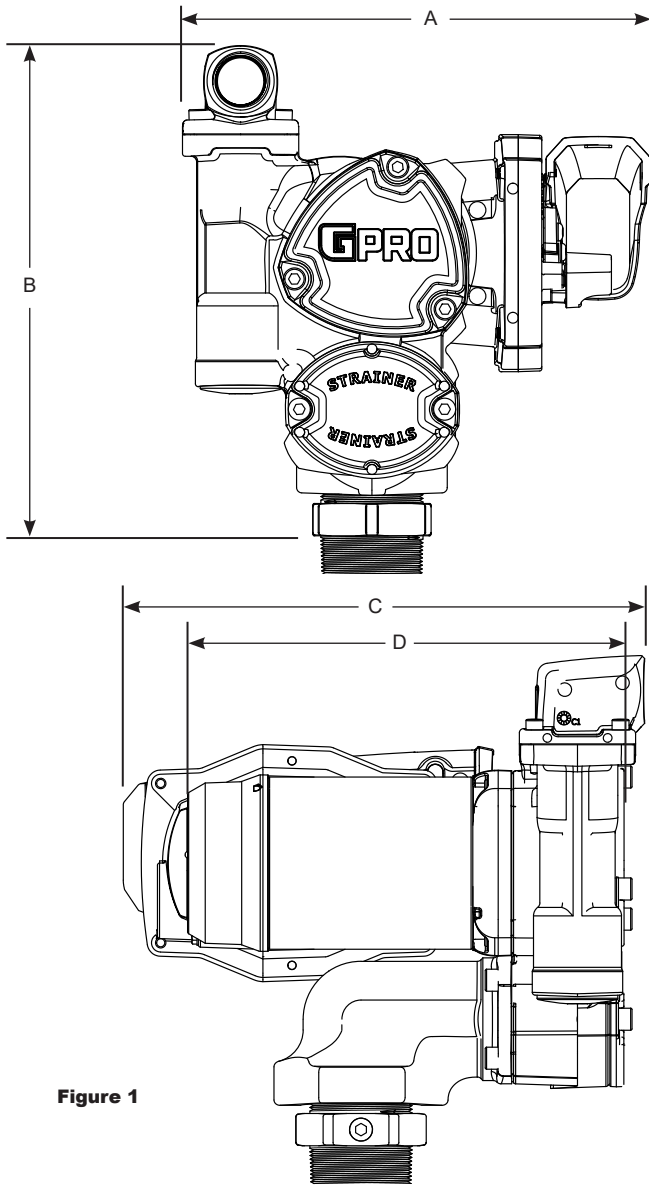

Figure 1

**SPECIFICATIONS (CONTINUED)****SAFETY TESTING APPROVALS**

The V25-012PX and V25-024PX have been tested for compliance to the standards issues by Underwriters Laboratories, IECEX, and ATEX.



UL 674 (Edition 5): Electric motors and generators for use in hazardous (classified) locations.

**IEC Information**

Marking string:

**Ex db IIA T4 Gb  
IECEX UL 19.0049X**

Standards used:

IEC 60079-0 (Edition 7.0): Explosive Atmospheres – Part 0: Equipment - General requirements.

IEC 60079-1 (Edition 7.0): Explosive Atmospheres – Part 1: Equipment protected by flameproof enclosures “d”.

IECEX specific conditions of use:

1. Flameproof joints are not intended to be repaired.
2. The special fasteners used as securing bolts for the end bell are made of Class 12.9 type fasteners. The special fasteners used for electrical cover plate attachment are made of Class 12.9 type fasteners.

**ATEX Information**

Marking string:

**CE<sub>2809</sub> Ex II 2 G Ex db IIA T4 Gb  
DEMKO 19 ATEX 2219X**

Standards used:

EN IEC 60079-0: 2018

EN 60079-1: 2014

ATEX specific conditions of use:

1. Flameproof joints are not intended to be repaired.
2. The special fasteners used as securing bolts for the end bell are made of Class 12.9 type fasteners. The special fasteners used for electrical cover plate attachment are made of Class 12.9 type fasteners.



**DECLARATION OF CONFORMITY****Declaration of Conformity**

We declare, that the product:

Product Name: 12 and 24 volt DC Electric Fuel Pump  
Model Numbers: V25-XXXPX

Conforms with the requirements of the Directive (s) below by compliance with the Standards subsequently listed:

1. Council Directive 2014/34/EU relating to Equipment or Protective System intended for use in Potentially Explosive Atmospheres,  
EN IEC 60079-0:2018  
EN 60079-1:2014

Supplementary Information:

Specific conditions of use:

- The flameproof joints are not intended to be repaired.
- The special fasteners used as securing bolts for the end bell are made of Class 12.9 type fasteners. The special fasteners used for electrical cover plate attachment are made of Class 12.9 type fasteners.

I the undersigned, hereby declare that the equipment specified above conforms to the above Directive(s) and Standard(s).

Signature:



Full Name:

Victor Lukic

Position:

President

Great Plains Industries, Inc.

Place:

Wichita, KS USA

June 2020

Notified Body: UL International Demko A/S

Borupvang 5A  
2750 Ballerup,  
Denmark

Identification No: 0539

EU-Type Examination Certificate No: DEMKO 19 ATEX 2219X Rev. 0



5252 E. 36th St. N. Wichita, KS 67220-3205  
316-686-7361 / f. 316-686-6746 / GPI.net

## INSTALLATION INSTRUCTIONS

**▲ WARNING**

*Cover plates protect the operator from moving parts. Never operate the pump without cover plates in place. Never apply electric power to the pump without cover plates in place. Always disconnect power before repairing or servicing.*

### **Mechanical Connections**

NOTE: All threaded fuel connections must be sealed with thread tape or a pipe thread sealing compound approved for use with petroleum fuels and tightened securely to prevent leakage.

NOTE: This pump must be mounted on a vented tank.

NOTE: This pump is designed to mount directly to a standard 2 in. male pump tank mount adapter (included).

### **Install Tank Adapter and Suction Pipe**

NOTE: For Aluminum Tank Installation - To prevent thread galling of aluminum fittings, always prepare the threads for assembly using an anti-seize compound such as Loctite® 567™, Herson® Dripstop® 940 or equivalent.

1. Wrap the threaded end of suction pipe with three or four turns of thread tape (see Figure 2). Thread the suction pipe into the inlet port on the bottom of the pump and hand tighten until snug.
2. Wrap the lower threaded end of the tank adapter with three or four turns of thread tape (see Figure 3). Insert suction pipe and tank adapter into threaded tank opening. Using a wrench, tighten the adapter snugly into the fuel tank.

NOTE: If your tank is 15" - 24" deep, do not use the included suction pipe extension; if your tank is 24" - 40" deep, attach the suction pipe extension (see Figure 4).

## INSTALLATION INSTRUCTIONS (CONTINUED)



Figure 2

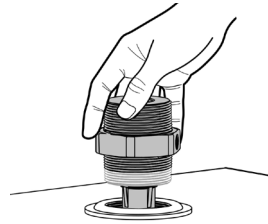

Figure 3



Figure 4

### **Install Pump on Tank**

1. Clean the tank interior of all dirt and foreign material.
2. Using pliers, remove the plastic plug from inlet port on bottom of pump. Wrap upper threads of tank adapter with three to four turns of thread tape, then using a wrench, tighten the pump onto the adapter.

### **Install Nozzle Cover**

1. Using a 4mm Hex wrench, install nozzle cover using (2) M6-1.0 x 14mm BHCS in lower hole (see Figure 5).

**NOTE:** For models V25-012PX and V25-024PX only, DO NOT install nozzle cover until after wiring is completed.

### **Install 1 in. NPT Outlet Adapter**

1. Remove plastic plug from outlet port of pump.
2. Install #222 O-ring into outlet port. Make sure O-ring is seated properly.
3. Using a 5mm Hex wrench, install the (4) M6-1.0 x 20mm SHCS into the 1 in. NPT outlet adapter in desired direction on outlet port (see Figure 5).

**INSTALLATION INSTRUCTIONS (CONTINUED)**

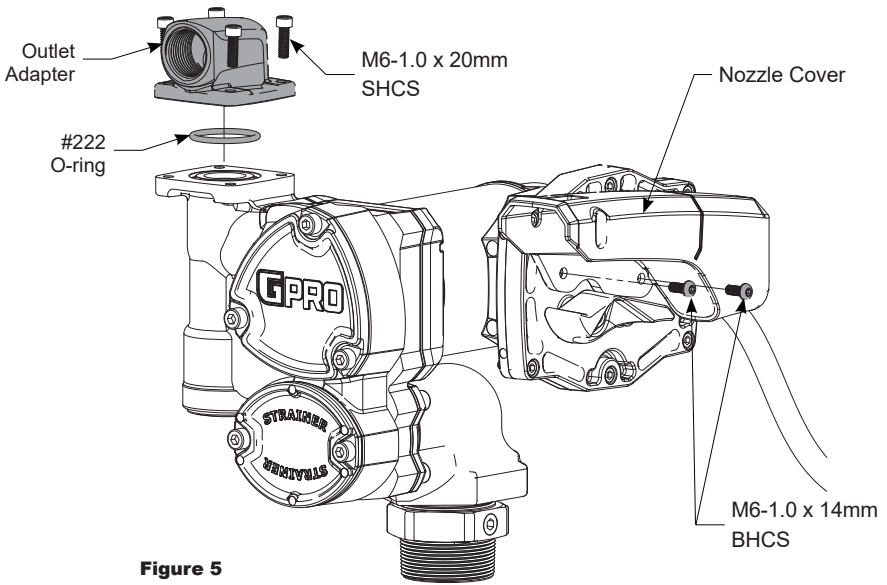

**Figure 5**

**Install Hose and Nozzle**

1. Wrap one end of the dispensing hose with three to four turns of thread tape and thread into outlet port. Tighten securely using an adjustable wrench.
2. Wrap opposite end of hose with three or four turns of thread tape and thread into nozzle. Tighten securely using an adjustable wrench.
3. Place the nozzle into the nozzle holder on the end of the pump motor housing. Note that the nozzle cannot be placed in the holder unless the pump switch is OFF (see Figure 9).

## INSTALLATION INSTRUCTIONS (CONTINUED)

### **Installation of V25-012PX or V25-024PX Model For DIV 1 (UL)**

**⚠ DANGER** *If the pump is to be installed in a Hazardous (Classified) location, it must be installed by a licensed electrician and conform to National Fire Protection Association (NFPA) codes 30 and 70. You as the owner, are responsible for seeing that the installation and operation of your pump complies with NFPA codes as well as any applicable state and local codes. Rigid conduit must be used to install wiring. Note that the lead wires are factory-sealed isolating the motor from the junction box.*

*Failure to follow these wiring instructions may result in death or serious injury from shock, fire or explosion.*

### **For Zone 1 or 2 (IECEx/ATEX)**

Use a suitable Ex db cable gland during Zone 1 or 2 installations. Power cord or cable (not supplied) should be compliant with Clause No. 10.6.2 of IEC 60079-14. Conductors used for line voltage must have insulation rated at 95 °C or above.

Motor bearings are sealed, no maintenance is required.

### **Installation of Other (non PX) Models**

**NOTE:** This pump is pre-wired for installation in CLASS I, DIVISION 2 locations such as portable fuel tanks, trailers, etc. Connection method to a battery will depend upon the application.

### **Installation Replacement Power Cord (DIV 2 ONLY)**

For installation in unclassified areas, the supplied power cord, fuse and strain relief grip may be used.

**NOTE:** These components have not been evaluated as part of the UL Listed Equipment and are not intended for use in a Hazardous (Classified) Location.

To install the power cord, remove the (6) M6-1.0 x 20mm SHCS and electrical cover plate (see Figure 7).

If necessary, trim the power cord to the desired length. Strip 3 to 4 inches (7.5 to 10 cm) of outer insulation from the power cord end. Then strip 1/2 inch (1.3 cm) of insulation from the power cord wires.

Slide the strain relief grip onto the power cord so that the threaded end of the strain relief grip faces the stripped power wires (see Figure 6).

Insert the power cord through the 3/4 inch NPT connection on the back of the pump (see Figure 7). Using wire nuts, connect the black wire to the black wire and the red wire to the red in the pump's electrical cavity. Position the wires inside the electrical cavity and tighten the strain relief grip securely. Make sure surfaces are clean. Reinstall the electrical cover plate and switch lever, and tighten securely.

**INSTALLATION INSTRUCTIONS (CONTINUED)**

**(Only for V25-012AD, V25-012MD, V25-024AD, and V25-024MD models)**

GETTING STARTED

SAFETY / SPECIFICATIONS

ASSEMBLY / INSTALLATION

OPERATION

TROUBLESHOOTING

MAINTENANCE / REPAIR

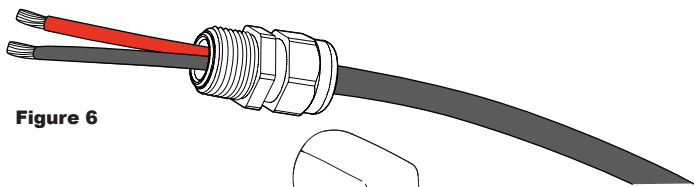

**Figure 6**

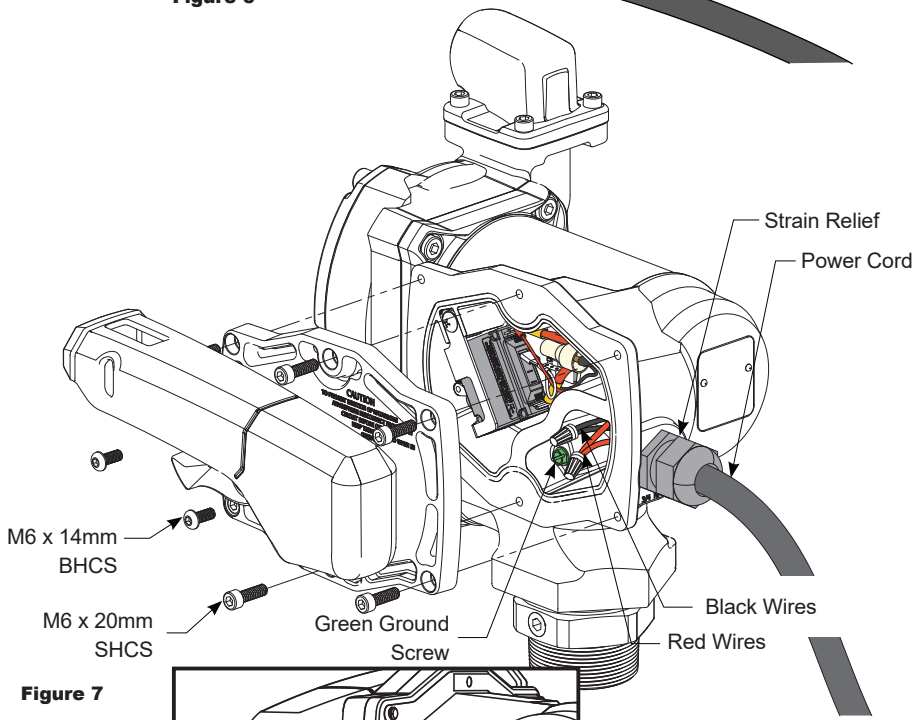

**Figure 7**

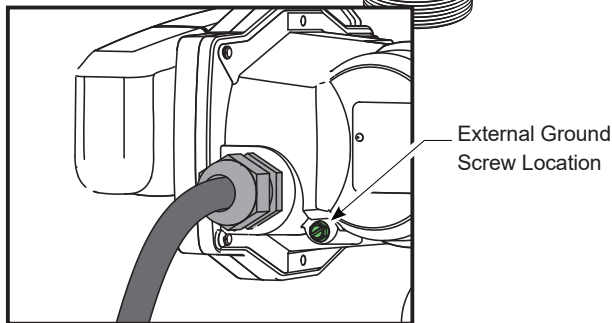

**Figure 7a**

**Install Ground Wire**

A grounding connection is provided. It is identified as a green colored binding head screw in the electrical cavity (see Figure 7): an external ground can be used instead. When using the external ground for the V25-012PX or V25-024PX (Zone 1 or 2), the installer **must** use a ground wire with a minimum cross-sectional area of 4mm<sup>2</sup>. To use external ground, remove green ground screw from electrical cavity and install in location shown (see Figure 7a).

## INSTALLATION INSTRUCTIONS (CONTINUED)

### Connect to a Power Source

**NOTE:** Please consult the Owner's Manual for your vehicle before proceeding.

**IMPORTANT:** Pumps are designed for use with a specific power source. Do not attempt connection of any pump to a power source that is not specified in this manual (see [BEFORE YOU BEGIN: Power Requirements](#)).

**▲ WARNING** Do not attempt to power the pump from vehicle wiring smaller than 10 gauge, such as the cigarette lighter wire, as thin wires could overheat and cause a fire.

**IMPORTANT:** Verify switch is in OFF position (see Figure 9), then route the power cord to the source of the vehicle power system. Be sure to support the power cord as necessary and protect it from sharp edges, heat, or anything that could damage it, resulting in a short circuit.

1. If the power cord provided is too long, cut to desired length. Using a utility knife, carefully strip 3 to 4 inches of outer insulation from end of power cord. DO NOT CUT INSULATION OF INNER WIRES. Using wire strippers, remove 1/4 in. of insulation from the black and red power cord wires.
2. Using wire strippers, carefully strip 1/4 in. of insulation from both ends of the fuse assembly wire.
3. Insert one end of the fuse assembly wire into a wire connector (included) and crimp. Insert the red power cord wire into the other end of the wire connector and crimp. Make sure the fuse assembly is positioned outside of hazardous areas and as close to the battery as possible (see Figure 8).
4. Using wire crimpers, attach a terminal post ring (included) to the other end of the fuse assembly and a terminal post ring to the end of the black power cord wire.
5. Connect the red wire/fuse assembly to the positive side of the battery (see Figure 8), and connect the black power cord wire to the negative side of the battery.

**NOTE:** Connecting directly to the battery terminal or the end of the battery cable is recommended.

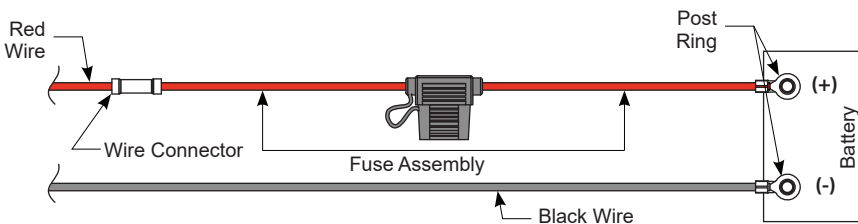

Figure 8

## OPERATION

**IMPORTANT:** Always follow safety precautions when operating this equipment. Review the Safety Instructions.

**⚠ DANGER** *To prevent physical injury or property damage, observe precautions against fire or explosion when dispensing fuel. Do not operate the system in the presence of any source of ignition including running or hot engines, lighted tobacco products, gas or electric heaters, or any type of electronic device. A spark can ignite fuel vapors.*

**⚠ CAUTION** *Before each use, repair leaks around seals or connections. Make sure hoses are in good condition and connections are tight.*

**NOTE:** Make sure the work area is dry.

**⚠ WARNING** *Make sure the pump is properly grounded. Repair any corroded or damaged wiring before use.*

**NOTE:** Ensure the tank contains enough fuel.

**IMPORTANT:** Make sure the fuel is not contaminated with debris. Tighten loose tank lids regularly.

### Dispensing Fuel

1. Remove the nozzle from holder and insert into receiving tank. Turn the pump on by pushing the switch lever up. Squeeze the handle to start fuel flow. When done, release the nozzle handle, turn the pump off, and return the nozzle to its holder.

**IMPORTANT:** This pump is designed to be self-priming. If fuel is not delivered within 15 to 20 seconds, turn the pump off and refer to priming information in the Troubleshooting Section.

**⚠ CAUTION** *An automatic bypass valve prevents pressure build up when the pump is on with the nozzle closed. To avoid pump damage, do not run the pump more than 10 minutes with the nozzle closed. Leaving the pump on with the nozzle closed for more than 10 minutes can damage the pump components and will void the warranty.*

**⚠ CAUTION** *Never leave the pump running without fluid. Dry running can damage the pump components, and will void the warranty.*

**IMPORTANT:** This is an intermittent duty pump, after running the pump for a maximum of 30 minutes, allow it to cool for 30 minutes.



## OPERATION (CONTINUED)

### Motor Protector

**NOTE:** This pump is equipped with a motor protective device that also serves as the ON/OFF switch. The motor protective device is not intended to provide branch protection.

1. If motor is overloaded, the protective device trips and opens the circuit. This feature protects the motor from damage and must be reset manually.
2. To reset, turn switch lever OFF and then back ON (see Figures 9 and 10).
3. If the protective device trips again quickly, disconnect from power source before attempting to troubleshoot the problem. Follow the instructions provided in the Troubleshooting section of this manual.
4. Make sure the switch lever is OFF before restoring power.
5. Turn switch lever ON and restart.

**NOTE:** In addition to overload protection, this pump is equipped with an auxiliary device that will automatically turn the pump OFF if it is left ON for longer than the duty cycle.

If the pump automatically shuts off after 30 minutes of use, turn the switch OFF and allow the motor to cool for 30 minutes. After cooling, the pump is ready for use again.

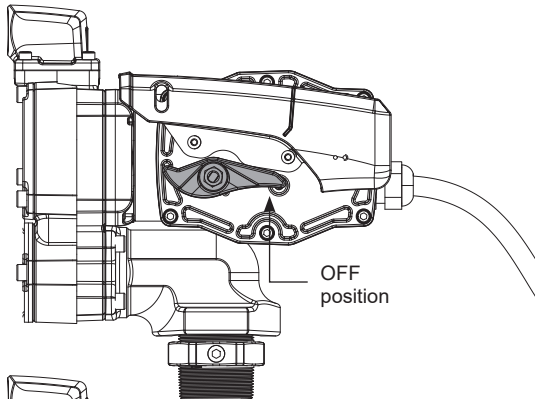

**Figure 9**

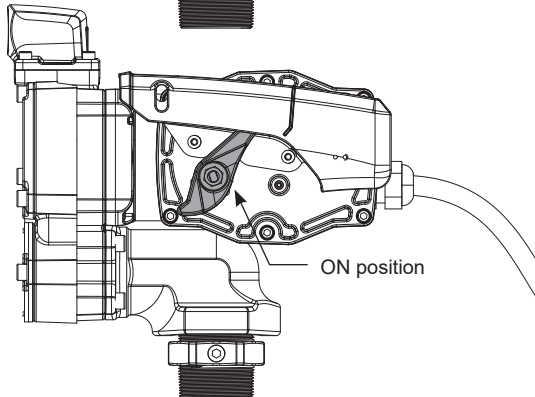

**Figure 10**

## TROUBLESHOOTING

Symptom	Possible Cause(s)	Corrective Action
A. Motor does not run	1. Fuse blown	1. Inspect fuse in fuse holder on power cord. If blown, replace
	2. Switch defective	2. Remove switch cover plate and inspect switch. Replace, if necessary
	3. Rotor or vanes are jammed	3. Remove cover plate to expose rotor. Remove any obstructions. Check for excessive vane and slot wear. Replace if damaged
	4. Circuit breaker tripped	4. Turn power off at source. Inspect the pump thoroughly; clean or repair. Reset circuit breaker by turning the power switch off then back on
	5. Duty cycle elapsed	5. Turn switch off. Allow 30 minutes of cool down time. Turn switch back on when ready to use
B. Motor runs but does not pump	1. Motor running backwards due to incorrect polarity	1. Connect red wire to positive (+) ungrounded side of battery. Motor shaft should turn counterclockwise
	2. Poor connections or low voltage	2. Make sure electrical connections are secure. Check battery voltage
	3. Fuel tank low/empty	3. Fill tank
	4. Strainer clogged or defective	4. Inspect strainer (see Maintenance/Repair section). Replace, if necessary
	5. System air leak	5. Tighten all pump fittings and connections. Inspect suction pipe for leaks or damage
	6. Suction pipe clogged, damaged or missing	6. Remove pump from tank. Inspect suction pipe. Clean or replace, as necessary
	7. Vanes worn or sticking	7. Check slots and vanes for excessive damage. Replace if damaged
	8. Bypass poppet O-ring worn or missing	8. Inspect O-ring (see Maintenance/Repair section). Replace, if necessary
	9. Bypass poppet binding or damaged	9. Remove the bypass poppet, spring, and O-ring. Clean cavity. Inspect and replace components, if needed

## TROUBLESHOOTING (CONTINUED)

Symptom	Possible Cause(s)	Corrective Action
C. Low flow rate	1. Strainer partially clogged	1. Inspect strainer (see Maintenance/Repair section). Replace, if necessary
	2. Poor connections or low voltage	2. Make sure electrical connections are secure. Also check battery voltage
	3. Fuel tank low/empty	3. Fill tank
	4. Suction pipe clogged or damaged	4. Remove pump from tank. Inspect suction pipe. Clean or replace, as necessary
	5. System air leak	5. Tighten all pump fittings and connections. Inspect suction pipe for leaks or damage. Replace, as necessary
	6. Strainer clogged or defective	6. Inspect strainer (see Maintenance/Repair section). Replace, if necessary
	7. Vanes worn or sticking	7. Check slots and vanes for excessive damage. Replace if damaged
	8. Bypass poppet O-ring worn or missing	8. Inspect O-ring (see Maintenance/Repair section). Replace, if necessary
	9. Bypass poppet binding or damaged	9. Remove the bypass poppet, spring, and O-ring. Clean cavity. Inspect and replace components, if needed
	10. Outlet is blocked	10. Check all accessories for blockage. Remove any obstructions
	11. Using off-the-shelf automatic nozzle	11. Factory-supplied automatic nozzle is recommended
	12. Hose damaged	12. Replace hose
D. Motor stalls when operating in bypass mode	1. Motor protector activated	1. Turn off switch. Allow motor to cool, then turn on switch
	2. Wiring defective	2. Use Wiring instructions in the Installation Section to ensure proper connections
	3. Bypass poppet binding or damaged	3. Using instructions in the Repair Section, remove the bypass poppet, spring and O-ring. Clean cavity. Inspect components and replace, as necessary
	4. Rotor or vanes worn	4. Check rotor and vanes for excessive wear. Replace as needed
	5. Motor damaged	5. Replace pump

## TROUBLESHOOTING (CONTINUED)

Symptom	Possible Cause(s)	Corrective Action
E. Switch fails to operate motor	1. Switch or electrical connections faulty	1. Inspect for blown fuse, defective wiring or switch, or improper electrical connections. Refer to Switch Replacement instructions in the Repair Section
	2. Motor protector activated	2. Turn off switch. Allow motor to cool, then turn on switch
	3. Motor damaged	3. Replace pump
F. Overheating of motor	1. Duty cycle too long	1. Pump operation should not exceed the standard duty cycle of 30 minutes ON, and 30 minutes OFF. Allow the pump to cool for 30 minutes
	2. Running too long in bypass mode	2. Limit bypass operation to 10 minutes
	3. Strainer clogged	3. Inspect strainer (see Maintenance/Repair section). Replace, if necessary
	4. Suction pipe clogged or damaged	4. Remove pump from tank. Inspect suction pipe. Clean or replace, as necessary
G. Fuel Leakage	1. Threaded joints loose	1. Check and reseal threaded joints
	2. Insufficient bolt torque	2. Retighten bolts
	3. Lost or damaged O-ring	3. Check O-rings for damage. Replace as needed
	4. Shaft seal worn or damaged	4. Fuel leaking from weep hole indicates shaft seal needs to be replaced
	5. Hose damaged	5. Replace hose

## MAINTENANCE

**NOTE:** This pump is designed for minimum maintenance. The motor bearings are self-lubricating. Inspect the pump and components regularly for fuel leaks and make sure the hose and power cord are in good condition. Keep the pump exterior clean to help identify leaks.

**IMPORTANT:** Do not use this pump for water, chemicals or herbicides. Dispensing any fluid other than those listed in this manual (see **BEFORE YOU BEGIN: Fueling Requirements** at front of manual) may damage the pump. Use of the pump with unauthorized fluids will void the warranty.

### Clean or Replace Check valve / Strainer

1. Turn the pump off and disconnect from power. Using 6mm hex wrench, remove the strainer access cover, O-ring, and check valve/strainer assembly and inspect for damage or clogs (see Figure 11). Clean the strainer with a soft-bristled brush and solvent. If the strainer is very dirty, compressed air may be used. If damaged, replace the check valve/strainer assembly.
2. Clean the strainer access cover and O-ring. Coat the O-ring lightly with grease. Reinstall the check valve/strainer, O-ring and strainer access cover. Ensure the O-ring is properly seated and tighten securely.

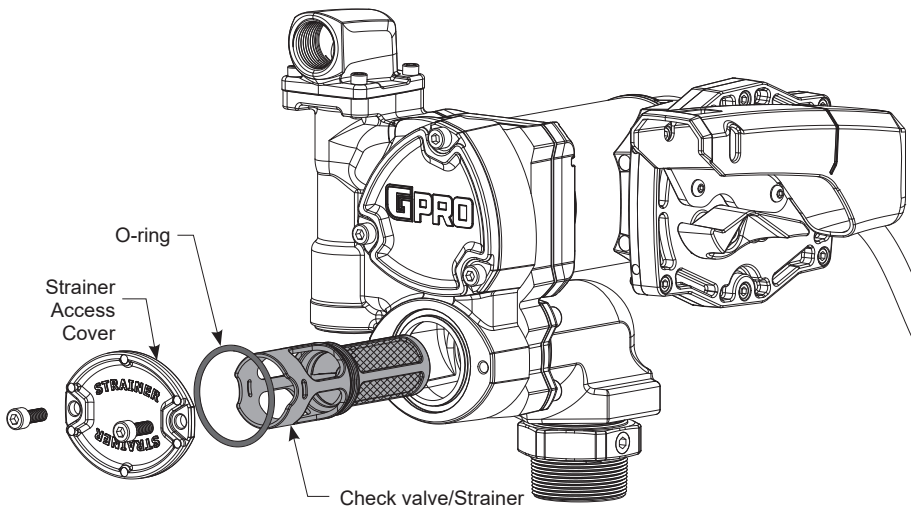

Figure 11

**REPAIR**

**IMPORTANT:** Carefully inspect all parts for wear or damage. Replace components, as necessary. The Illustrated Parts List gives information on replacement parts and kits. Review the Safety Instructions before proceeding.

**⚠ DANGER** *Observe precautions against electrical shock when servicing the pump. Always disconnect power before repairing or servicing. Never apply electrical power to the system when any of the cover plates are removed.*

**⚠ WARNING** *Avoid prolonged skin contact with petroleum fuels. Use protective goggles, gloves and aprons in case of splashing or spills. Change saturated clothing and wash skin promptly with soap and water.*

**Service O-rings**

**NOTE:** A Wet Seal Kit contains all seals for your pump and should be on hand when performing repairs. Old seals may then be replaced with new seals.

1. In general, when inspecting O-rings, look for breaks, wear, and signs of deterioration, such as swelling.
2. Replace, as necessary.
3. Before seating, coat O-rings with light grease.

## REPAIR (CONTINUED)

### Replace Vanes

1. Turn the pump OFF and disconnect from power.
2. Using 6mm hex wrench, remove the cover plate and O-ring (see Figure 12).
3. Remove the rotor, shaft key, and vanes.
4. Remove the shaft key, rotor, and vanes.
5. Inspect vanes for wear and damage. Replace as necessary.
6. Wipe the rotor pocket with a clean cloth.
7. Remove the rotor, shaft key, and vanes.
8. Replace the rotor, shaft key, and vanes, making sure the vanes are oriented with flat side facing forward (as shown in Figure 12a).
9. Make sure the cover plate O-ring is securely in place. Tighten the cover plate to the housing.

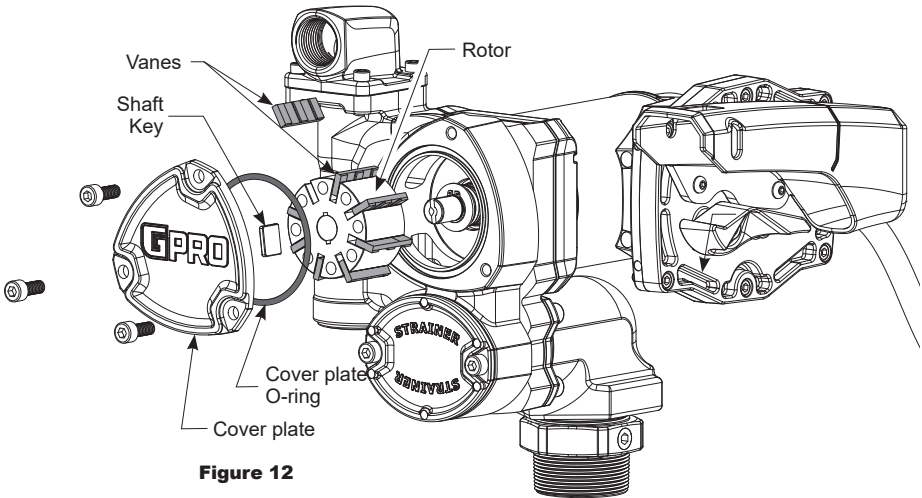

**Figure 12**

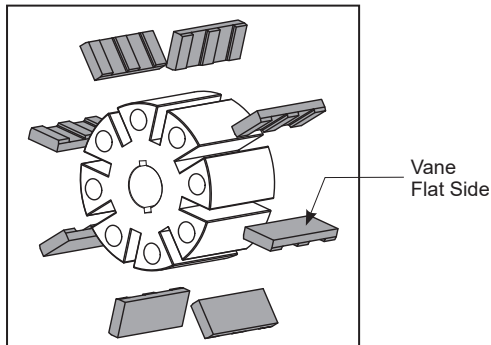

**Figure 12a**

## REPAIR (CONTINUED)

**Clean and Replace Bypass Poppet**

1. Turn the pump OFF and disconnect from power.
2. With a 10mm Hex wrench remove the bypass plug from the pump, and remove the bypass poppet spring, O-ring, bypass poppet and orifice seal (see Figure 13).
3. Inspect the O-ring and replace as necessary

**NOTE:** Replace O-ring if damaged, swollen or loose-fitting (see Seal Kit).

4. With a clean cloth, wipe the poppet components and replace.
5. Before seating, coat O-ring with light grease.

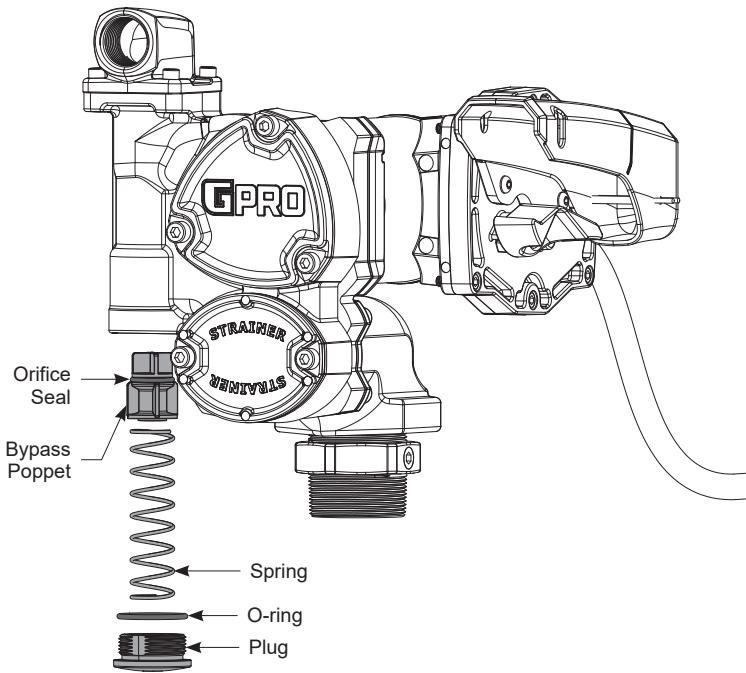

**Figure 13**



## REPAIR (CONTINUED)

### Replace Power Switch

1. Turn the pump OFF and disconnect from power.
2. Using a 4mm Hex wrench remove the (2) BHCS and nozzle cover.
4. Remove the (6) M6 SHCS and electrical cover plate from the motor housing.
5. Remove the (1) #10 truss head screw and switch bracket with switch assembly (see Figure 14).
6. Unscrew both #6 machine screws and remove the switch assembly from the switch bracket.
7. Unscrew/unplug three blade terminals and remove red and white wires from the switch (see Figure 14). Take note of which wire is attached to each blade terminal for reinstallation.
8. Install a new switch by reversing the above procedure. Insert the switch assembly into the pump cavity. Reinstall all components and tighten bolts securely.

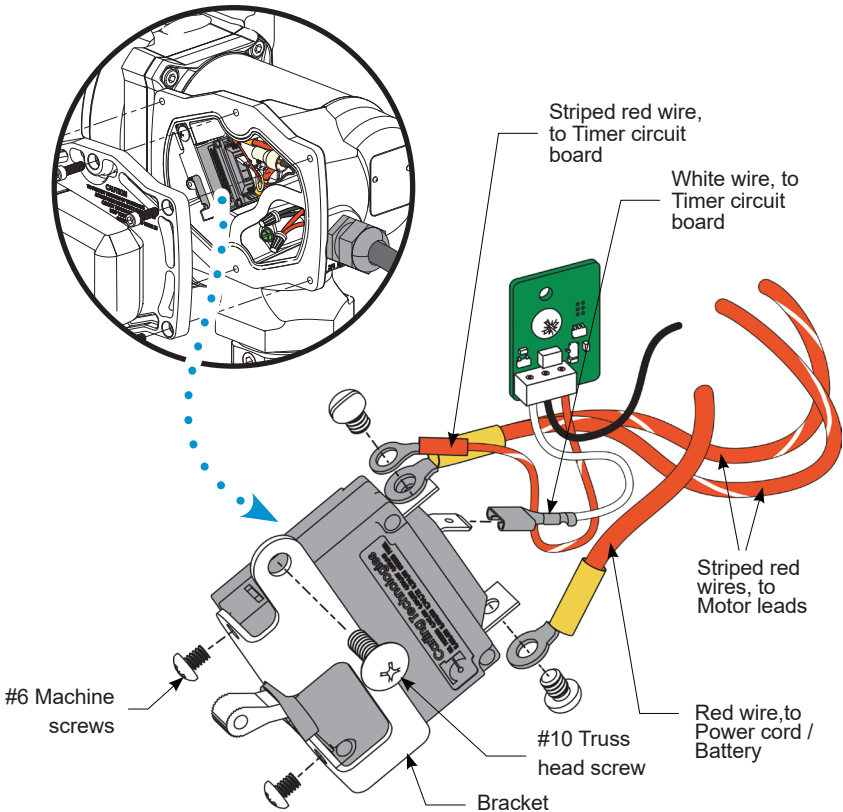
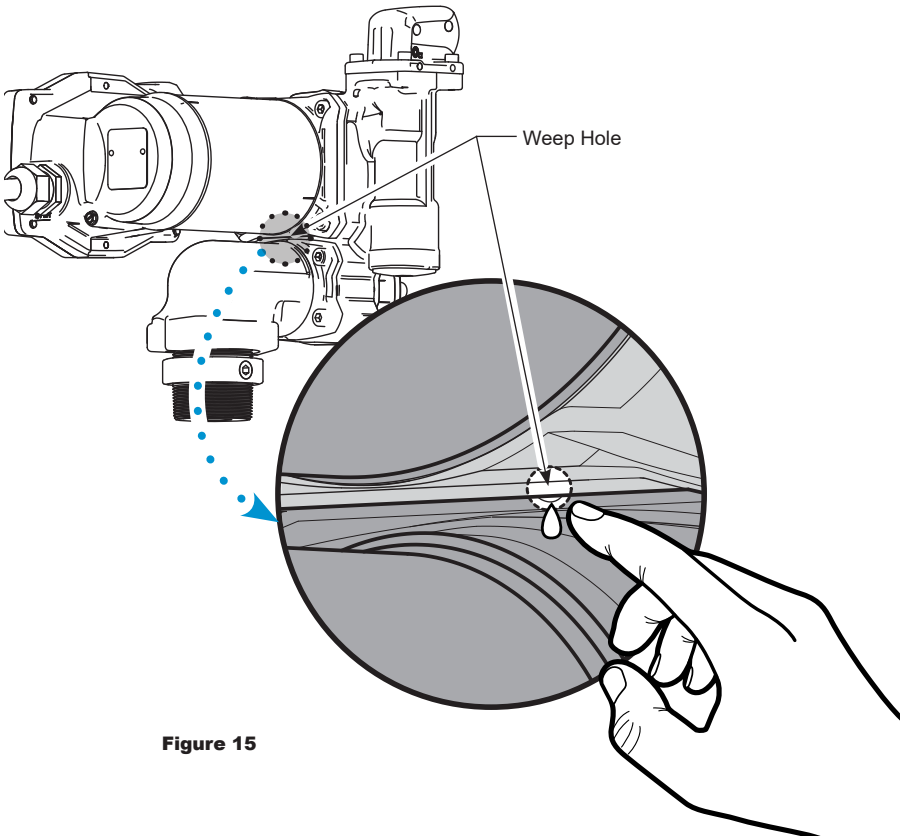

Figure 14

**REPAIR (CONTINUED)****Check Motor Shaft Weep Hole**

1. Locate small weep hole below the motor housing, on the back of the pump housing to check for a motor shaft seal leak (see Figure 15).
2. A wet or leaking weep hole indicates a worn or damaged shaft seal. To eliminate the leak replace the shaft seal (see Shaft Seal Kit or Extreme Temp Shaft Seal Kit).

**Figure 15**

## REPAIR (CONTINUED)

### **Replace Motor Shaft Seal**

1. Turn the pump OFF and disconnect from power.
2. Using a 6mm Hex wrench, remove cover plate (see Figure 16). Remove cover plate O-ring.
3. Remove shaft key, rotor, and vanes. Remove vanes and key first before removing rotor to prevent them from falling into pump inlet (see Figure 16).
4. Using snap ring pliers, remove retaining ring, being careful not to damage motor shaft or housing bore (see Figure 16). Remove washer and motor shaft seal. Discard these three parts.
9. Locate new shaft seal kit, or extreme temp series shaft seal kit and follow included instructions for installation.
10. Reinstall rotor, key, and vanes.
11. Reinstall cover plate O-ring and cover plate. Tighten bolts.

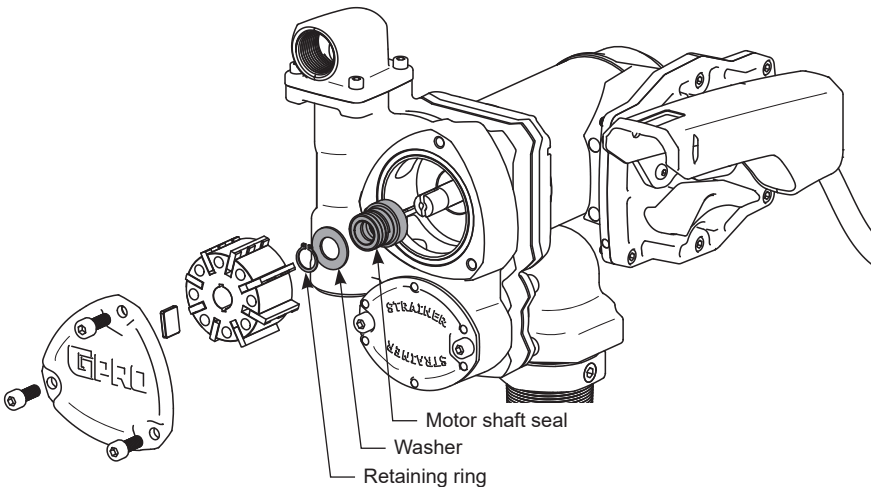

**Figure 16**

### **Remove Pump From Tank**

1. Turn the pump OFF and disconnect from power.
2. Unthread and lift the pump from the tank adapter.
3. Elevate the nozzle and hose to allow excess fuel to drain into the tank.
4. Wipe the entire system with a clean cloth.

## REPAIR PARTS ILLUSTRATION FOR ALL MODELS

### ⚠ CAUTION

Do not return the pump or parts without prior approval from the GPI Customer Service Department. Due to strict government regulations, GPI cannot accept parts unless they have been drained and cleaned.

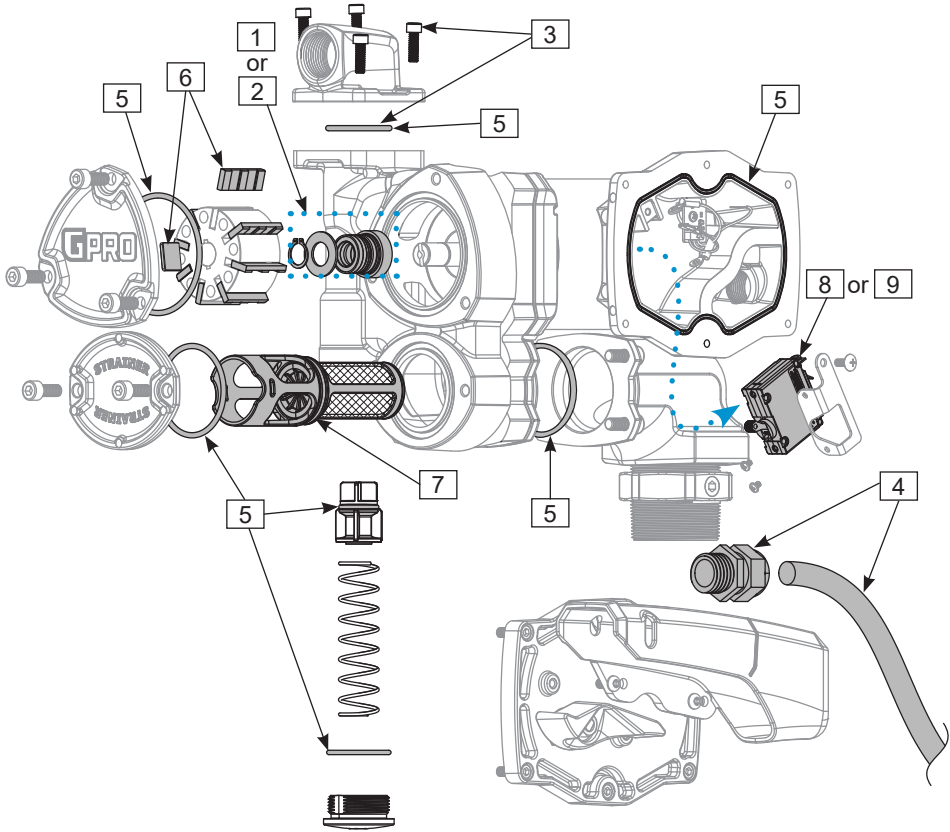

## PARTS & SERVICE

For warranty consideration, parts, or other service information, please contact your local distributor. If you need further assistance, contact the GPI Customer Service Department in Wichita, Kansas, during normal business hours.

A toll free number is provided for your convenience.

**1-800-835-0113**

To obtain prompt, efficient service, always be prepared with the following information:

- The model number of your pump.
- The serial number or manufacturing date code of your pump.
- Part descriptions and numbers.

For warranty work, always be prepared with your original sales slip or other evidence of purchase date.

## REPAIR PARTS LIST FOR ALL MODELS

Ref. No.	Description	Part Number	Qty.
1	<b>Shaft Seal Kit</b>	<b>133503-1</b>	
	Shaft Seal	▲	1
	Retaining Ring	▲	1
	Washer	▲	1
2	<b>Shaft Seal Kit, Extreme Temp Series</b>	<b>133503-05</b>	
	Shaft Seal, Extreme Temp Series	▲	1
	Retaining Ring	▲	1
	Washer	▲	1
3	<b>Outlet Hardware Kit</b>	<b>162516-503</b>	
	5mm Hex Key (not shown)	▲	1
	M6-1.0 x 20mm SHCS	▲	4
	Outlet Port O-ring #222	▲	1
4	<b>Power Cord Kit</b>	<b>170511-01</b>	
	Power cord	▲	1
	Strain relief	▲	1
5	<b>Seal Kit</b>	<b>170512-01</b>	
	Cover plate O-ring #234	▲	1
	Strainer Access/Centering Base O-ring #228	▲	2
	Outlet Port O-ring #222	▲	1
	Bypass Plug O-ring #920	▲	1
	Bypass Poppet O-ring	▲	1
	Electrical Cover plate Seal	▲	1
6	<b>Vane Kit</b>	<b>170513-01</b>	
	Cover plate O-ring #234	▲	1
	Vanes	▲	8
	Shaft Key	▲	1
7	<b>Strainer Assembly</b>	<b>170211-501</b>	1
8	<b>12V Switch Assembly</b>	<b>902010-525</b>	1
9	<b>24V Switch Assembly</b>	<b>902010-531</b>	1

(▲) Available as part of kit only.

**IMPORTANT:** Please contact GPI before returning any parts. It may be possible to diagnose the trouble and identify needed parts in a telephone call. GPI can also inform you of any special requirements you will need to follow for shipping fuel dispensing equipment.

**IMPORTANT:** In order to preserve the UL Listing for the motor, do not attempt to service the motor. For products serviced outside the factory, the UL nameplate must be defaced to indicate that the equipment may no longer meet the requirements for UL Listing. This does not apply to products serviced outside the factory under the UL program for Rebuilt Motors for Use in Hazardous Locations.





## **GPRO® FOUR-YEAR LIMITED WARRANTY**

Great Plains Industries, Inc. 5252 E. 36th Street North, Wichita, KS USA 67220-3205, hereby provides a limited warranty against defects in material and workmanship on all products manufactured by Great Plains Industries, Inc. This product includes a 4 year warranty from date of purchase as evidenced by the original sales receipt. A 54 month warranty from product date of manufacture will apply in cases where the original sales receipt is not available. Reference product labeling for the warranty expiration date based on 54 months from date of manufacture. Manufacturer's sole obligation under the foregoing warranties will be limited to either, at manufacturer's option, replacing or repairing defective goods (subject to limitations hereinafter provided) or refunding the purchase price for such goods theretofore paid by the buyer, and buyer's exclusive remedy for breach of any such warranties will be enforcement of such obligations of manufacturer. The warranty shall extend to the purchaser of this product and to any person to whom such product is transferred during the warranty period. This warranty shall not apply if:

A. the product has been altered or modified outside the warrantor's duly appointed representative;

B. the product has been subjected to neglect, misuse, abuse or damage or has been installed or operated other than in accordance with the manufacturer's operating instructions.

To make a claim against this warranty, contact the GPI Customer Service Department at

**316-686-7361 or 800-835-0113.**

**Or by mail at:**

**Great Plains Industries, Inc.**

**5252 E. 36th St. North**

**Wichita, KS, USA 67220-3205**

The company will guide you through a product troubleshooting process to determine appropriate corrective actions.

**GREAT PLAINS INDUSTRIES, INC., EXCLUDES LIABILITY UNDER THIS WARRANTY FOR DIRECT, INDIRECT, INCIDENTAL AND CONSEQUENTIAL DAMAGES INCURRED IN THE USE OR LOSS OF USE OF THE PRODUCT WARRANTED HEREUNDER.**

The company herewith expressly disclaims any warranty of merchantability or fitness for any particular purpose other than for which it was designed.

This warranty gives you specific rights and you may also have other rights which vary from U.S. state to U.S. state.

Note: In compliance with MAGNUSON-MOSS CONSUMER WARRANTY ACT – Part 702 (governs the resale availability of the warranty terms).

Wichita / Sydney

**GREAT PLAINS INDUSTRIES**



© 2020 Great Plains Industries, Inc., All Rights Reserved.

**Great Plains Industries, Inc. / 800-835-0113 / GPI.net**