

120 GALLON DOUBLE WALL TANK

29"x34"x37.5"x12Gauge Mild Steel

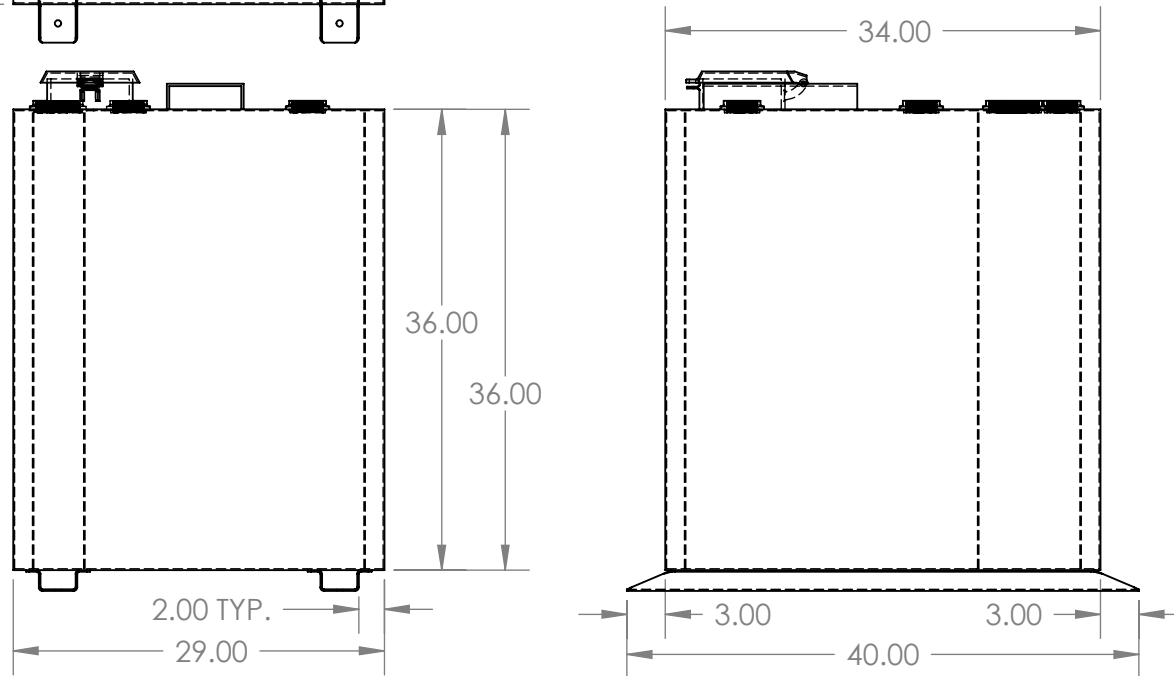
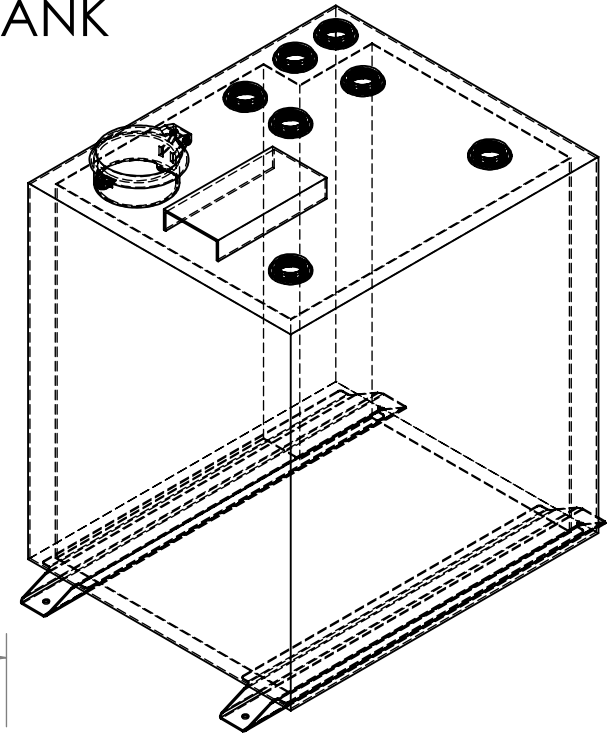
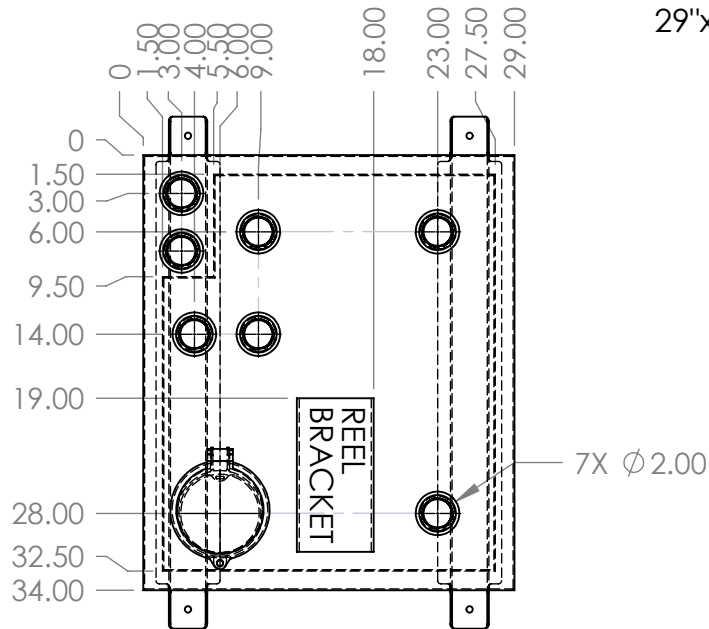

- (1) 6" Hatch
 - (5) 2" FNPT in Primary
 - (2) 2" FNPT in Annular Space
 - (1) 6"x12" Reel Mount
 - (2) Extended Tank Support
- Tank Factory Tested at 3 PSI
 Powder Coat Finish
 UL142, File # MH14783
 1 Year Warranty on Material
 and Workmanship
 *No provision for Lost Product or Business

PROPRIETARY AND CONFIDENTIAL



THE INFORMATION CONTAINED IN THIS DRAWING IS THE SOLE PROPERTY OF SUPERIOR STORAGE TANKS. ANY REPRODUCTION IN PART OR AS A WHOLE WITHOUT THE WRITTEN PERMISSION OF SUPERIOR STORAGE TANKS IS PROHIBITED.

14700 Industry Circle
 La Mirada, CA 90638

Gallons
 120
 Label
 UL-142
 Secondary
 Containment

MATERIAL
 12ga.
 Mild Steel
 A-36
 Unless Otherwise Noted

SIZE NAME:

C

Drawn By: D. Do

WEIGHT: 445 lbs.

120DW-ES

DATE: 7/9/2015

SCALE: 1:15

SHEET 1 OF 1