

# Oil King,<sup>™</sup> Coolant King<sup>™</sup> and Oil Ace<sup>™</sup> Fluid Reclaim Packages and Accessories

## Oil King and Coolant King

- Large 25 gallon capacity with sight gauge
- Convenient tool trays and filter areas
- Large offset collection pan with screen
- Oversized tires to get over hose and rough floors
- Color specific receiver for easy identification

## Typical Applications

- Used fluid receiver
- Automotive dealerships
- Heavy-duty dealerships
- Fast lube centers
- Fleet service facilities
- Service shops

## Typical Fluids Handled

- Used oil—Oil King
- Used antifreeze—Coolant King

## Ordering Information

Oil King Oil Receiver	
238866	25 gal (95 l) Polyethylene tank with used-filter tray, tool holders and sight gauge. Includes all hardware for topside evacuation or bottom drain*. Instruction manual 308667
Coolant King Anti-Freeze Receiver	
248632	25 gal (95 l) Polyethylene tank with used-filter tray, tool holders and sight gauge. Includes all hardware for topside evacuation or bottom drain*

\* Must use 224873 for topside evacuation. Must ship via truck.



238866



248632

## Oil Ace

- Easy to drain using shop air pressure
- Large 24 gallon capacity
- Large offset collection pan with screen

## Typical Applications

- Pressurized used oil receiver
- Automotive dealerships
- Heavy-duty dealerships
- Service shops
- Fast lube centers
- Fleet service facilities

## Typical Fluids Handled

- Used oil

## Ordering Information

Oil Ace	
119577	24 gal (90 l) Steel-tank Pressurized Oil Drain



119577

# Oil Receivers and Drains

## Fluid Reclaim Packages and Accessories

### Ordering Information

16 gal (60 l) Used-Oil Receiver with drum	
239301	Use with evacuation kit 240832. Instruction manual 306449
16 gal (60 l) Used-Oil Receiver without drum	
239302	Instruction manual 306449
Funnel Kit	
243650	Use with 238866, 239301, 239302 and 248632. Includes tray and pipe
Wall-Mounted Funnel Drain	
154616	Use with Pedestal Receiver 225272 to open automatic check-valve and drain used oil through wall to waste tank. Drain has 1-1/4 npt(f) outlet
Drum-Mounted Funnel Drain	
156789	Use with Pedestal Receiver (225272) to open automatic check-valve and drain used oil into standard drum. Funnel drain has 2 npt bung fitting for use with 55 gal (210 l) or 16 gal (60 l) drums, or 275 gallon (1,100 l) tanks
ATF Drain Funnel	
208009	Use with Pedestal Receiver (225272) to extend funnel reach. Use for draining transmissions. (Not equipped with drain plug.) 16 in x 24 1/2 in
Rolling Used-Oil Receiver	
218969	Specially designed for car and truck fast-lube facilities where speed and mobility are important. Adjustable steel rollers fit track widths of 39 in (99 cm) to 46 inches (117 cm), with a minimum running width of 2-1/2 in (63.5 mm). Front and rear drain fittings allow use of two drains on a single track, permitting two receivers to be drained simultaneously. Instruction manual 307727. Unit includes 30 gal (114 l) steel tank, 1-1/2 npt drain valve (108204), 1-1/2 npt quick coupler (108202) and 1-1/2 npt coupler cap. Dimensions: 24 in (61 cm) wide; 33 in (84 cm) long; 11 in (28 cm) deep; 3 in (7.6 cm) diameter wheels. 1-1/2 in drain hose—see manual provided
Narrow Rolling Used-Oil Receiver	
235346	Same as 218969 above, except track width range is from 34.2 in (87 cm) to 42.2 in (108 cm), 27 gal (102 l) capacity. Instruction manual 307727. See accessories on page 101
Big Hauler™ Truck Drain	
244055	Specially-designed for truck maintenance facilities, the Big Hauler Truck Drain boasts a large capacity and easy maneuverability. Dimensions: 42 in (106.7 cm) long; 30 in (76.2 cm) wide; 9 in (22.9 cm) deep. Capacity: 26 gallons (98 l). Instruction manual 309194. Gravity drain valve at bottom of unit allows for easy drain access. 3/4 in npt outlet can also be used with 224873 for diaphragm evacuation. 240832 can be ordered separately for existing diaphragm pump evacuation systems. Instruction manual 308719



239301



244055



208009



218969

# Oil Evacuation

## Fluid Reclaim Packages and Accessories

### Packages for Used-Oil Evacuation with Air-Operated Diaphragm Pumps

Wall-Mounted Packages	
24E166	Includes: 1050A (1 in) diaphragm pump (647016), wall bracket (24C637), air installation kits (240684), fluid installation kits (240685), drum style adapter kits (240832) <i>NOTE: Used-oil receivers are not included and must be ordered separately. See instruction manual 313597 for more information.</i>
224873	Includes: 716 (3/4 in) diaphragm pump (241906), wall bracket (224835), air installation kits, fluid installation kits (240685), drum style adapter kits (240832) <i>NOTE: Used-oil receivers are not included and must be ordered separately.</i>

**Stationary Gear-Oil Evacuation Systems with 716 or 1050 Diaphragm Pump**

System evacuates lube from differential case using suction generated by a diaphragm pump. Nylon tubes ranging in size from 3/16 in OD to 1/2 in OD are included to fit through sight plug to completely drain the case. Evacuated gear lube is then pumped to waste tank. Piping and waste tank not included. Systems are fully-groundable and bondable for safe transfer of used oil

224955	Includes: 716 diaphragm pump (241906), air control kit (110149), mounting kit (224759), swivel union (157785), hose coupler (111474), suction hose/wand** (221146) and control valve** (220969) <i>**Order additional suction hose/wand (221146) and additional control valve (220969) for each additional suction point. Note: Order grounding clamp (222011) or use locally-supplied grounding wires and clamps in accordance with applicable codes.</i>
24E167	Includes: UL-listed 1050A diaphragm pump (647016), air control kit, hose and fitting kit (222149), evacuation, suction hose/wand** (221146) and wall bracket (24C637) <i>**Order additional suction hose/wand 221146 and additional control valve 220969 for each additional suction point. Note: Order grounding clamp 222011 or use locally-supplied grounding wires and clamps in accordance with applicable codes. See instruction manual 313597 for more information.</i>

Port-Evacuation Pump	
223695	Port-Evacuation allows fast, clean withdrawal of gear lube, ATF, anti-freeze, and related fluids. Includes: 716 diaphragm pump (241906), mounting kit with 10 ft (3 m) suction hose (223697) which attaches to wands of four different diameters (suction wand kit, 223696): 1/2 in (12.7 mm); 3/8 in (9.5 mm); 1/4 in (6.4 mm), and 3/16 in (4.7 mm). Instruction manual 308035

Suction Wand Kits	
223696	15 in (38.1 cm)
224762	48 in (121.9 cm)

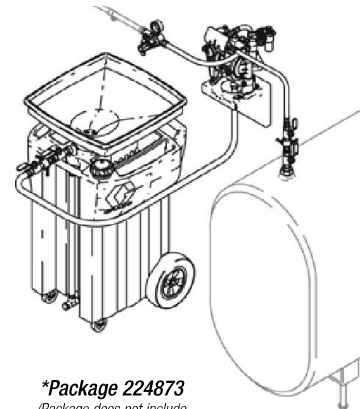

**\*Package 224873**  
(Package does not include 238866 receiver or tank)

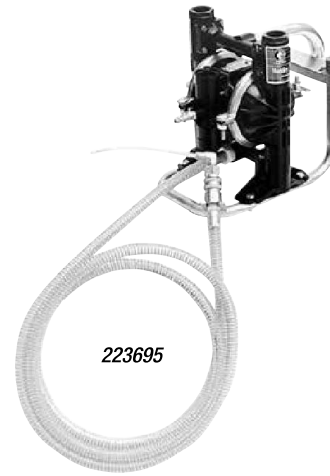

223695

### Used-Oil Handling Accessories

4-Way Evacuation Valve	
120581	1" npt (f) 4-way evacuation valve
120601	1.5" npt (f) 4-way evacuation valve

Tandem Drain Kit	
218970	Tandem drain kit connects two rolling receivers for flow-through draining operation. Kit includes connector hose, shut-off valve, pipe nipple, and quick-connect nipple. Instruction manual 307727
108491	Drain hose kit allows rolling used-oil receiver to be drained directly into the used-oil line. Kit is 24 in (0.6 m) in length with camlock coupler on one end

Swing-Arm Drain Kit	
221007	Used for servicing single rolling used-oil receiver (218969). When used with tandem drain kit (218970) it can service two receivers on a single track. Kit includes swivel elbow (108867), connector hose, dust cap (108203) and male adapter (108202)

Oil Tank Monitor	
116229	Shuts off air to the pump when tank is full.

Accessories for Port-Evac Pump (223695)	
223888	6 ft (1.8 m) suction hose for ATF and anti-freeze. Includes filter screen



120581



218970



116229

223888