

# NATIONAL-SPENCER, INC.

## ZEE LINE LUBRICATION EQUIPMENT

Phone 800-231-1525

Fax 800-637-9511

Web Address [www.zeeline.com](http://www.zeeline.com)



### Part #328

Grease Filler Pump  
For 25-50 lb. Container

For filling hand grease guns  
without disassembly



#### Features

- ❖ Fits 25 to 50 lb. container
- ❖ Pump length 18"
- ❖ Drum cover diameter 12"
- ❖ Rubber lined follower plate
- ❖ Adjustable pivot point handle allows for delivery of up to 14 oz. per each 15 strokes
- ❖ Zinc plated pump
- ❖ Die cast aluminum head
- ❖ Cast aluminum adjusting flange, cover and loader fitting
- ❖ Female and male loader adapters included

#### Recommended for

- ✓ Grease guns with .58 male loader fittings
- Up to and include # 2 grease

#### Application

- Automotive
- Industrial
- Agricultural

#### Number of boxes and contents

- 1 attractive retail box (20" x 13" x 4") (12 lb.)
- UPC Code 0 1595400328 1

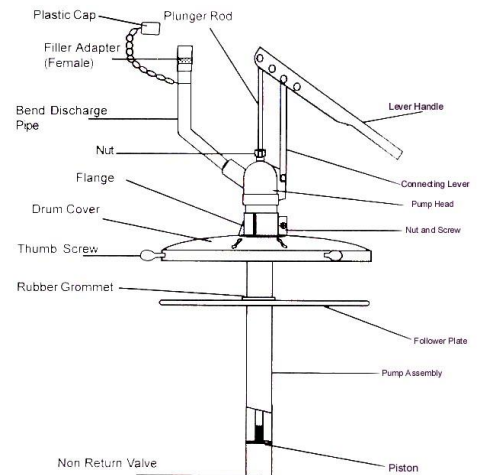

01/06/15